

JSK DH

The fully air operated dual-height fifth wheel system

www.jost-world.com

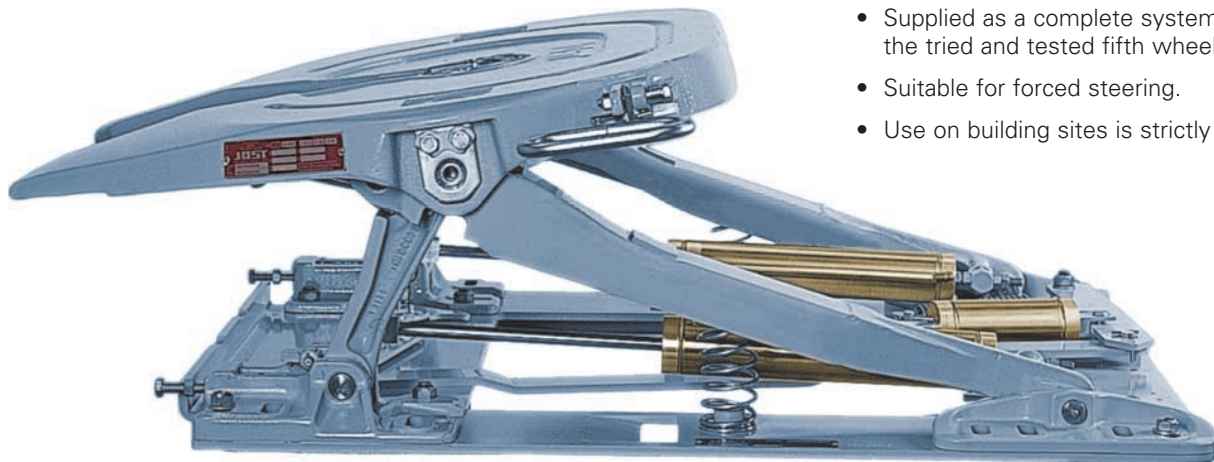

Universal application

- Enables low deck tractor units to tow not only megas, but also conventional semi trailers.
- Simple installation to virtually any tractor unit with standard bolts.
- Supplied as a complete system together with the tried and tested fifth wheel JSK 37 E.
- Suitable for forced steering.
- Use on building sites is strictly prohibited.

Safe and simple operation

- Dual safety locking mechanism
- Additional safety device to avoid false coupling
- Efficient and simple actuating system
- Can be locked, unlocked, raised and lowered in only a few seconds by means of pneumatic cylinders.
- The fifth wheel is easy and safe to use and has an extended handle for ease of operation.

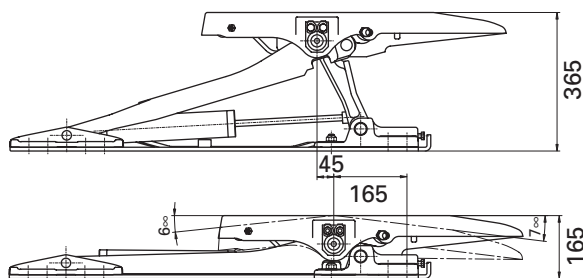

Robust, compact and light

- Total height in lower position only 165 mm
- 20 % to 40 % lighter than its predecessor
- Cathodic priming for long term corrosion protection

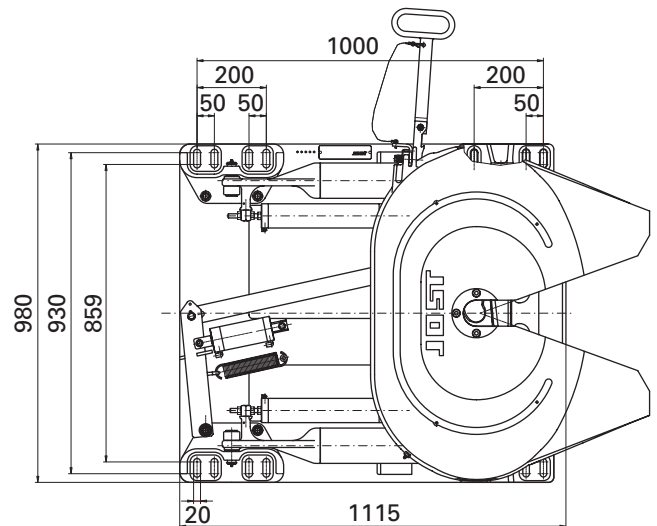

Technical details:

- Gross combination weight: 44.000 kg
- Imposed load: 15.000 kg
- D-value: 110 kN
- Weight: approx: 260 kg
- Type approval EC: e1 00-1069

Scope of supply:

Order No. JSKDHE02806AA

- Dual height unit with fifth wheel coupling JSK 37 E
- Fixing bolts
- Control-box
- Mounting and operating instructions

JO ST