

RO★KU 80

BEST BRAND

Reader's Choice 2005-2009:
Best towing hitch!

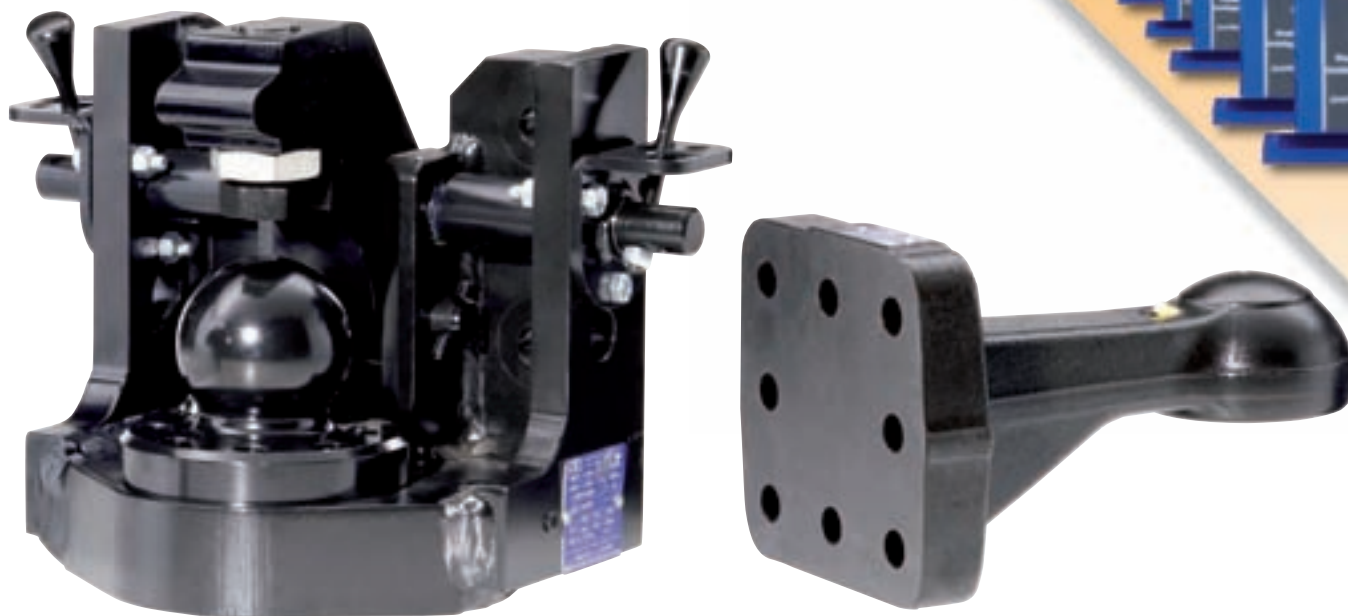

Ball Coupling System 80 mm for Car Carrier

- Easy to exchange (standard oval hole G6), lockable
- Innovative locking system ensures simple and safe operation
- Zero backlash guarantees optimal ride comfort
- Integrated sealing ring provides for a long product life and low wear
- Less wear of the towing eye and ball due to additionally installed lubricant reservoirs

www.jost-world.com

JOST

RO★KU 80

Technical Specifications



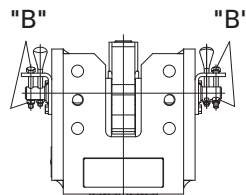
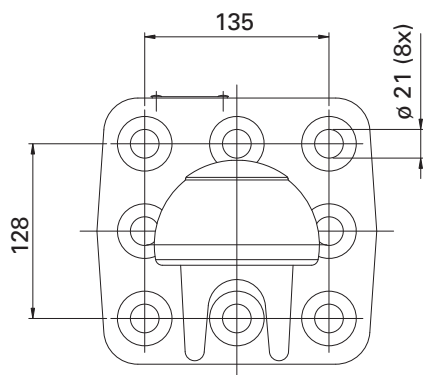
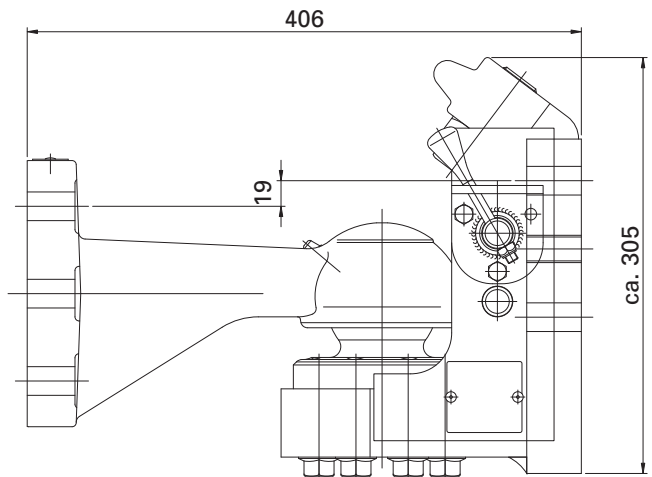
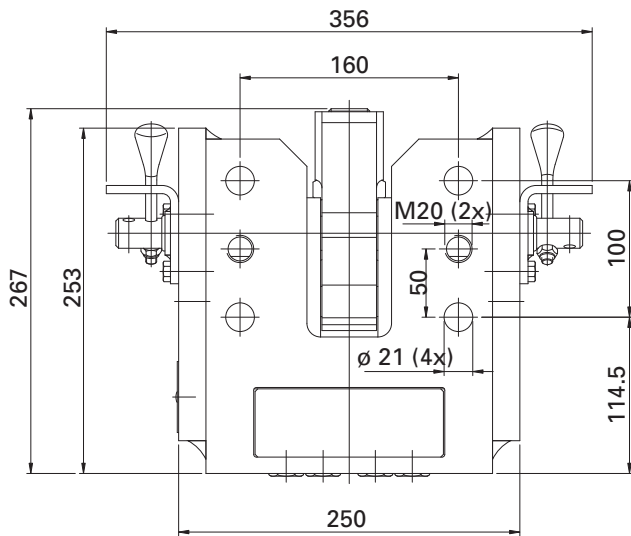



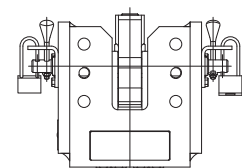



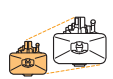

Ball Coupling System 80 mm













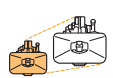

According to ECE55 Class T, the two locking bolts must be fixed with one screw each (B).



According to the EC94/20, in this position both locking bolts can be secured with two U-locks against unauthorized opening.

 		 (mm)	  D (kN)		 Dc (kN)		 S (kg) V (kN)		 Complete with drawbar eye (kg)	e1/ECE
			 R	 C			Complete with drawbar eye (kg)			
RO908H61000	6	160x100	140,0	140,0	1000	90	65,4	EG/94/20/S		
RO908H61000	6	160x100	140,0	140,0	2500	75	65,4	EG/94/20/S		
RO908H61000	6	160x100	-	140,0	1000	90	65,4	ECE 55/T		
RO908H61000	6	160x100	-	140,0	2500	75	65,4	ECE 55/T		

Bolt kit 85 mm

 		 (mm)	  D (kN)		 Dc (kN)		 S (kg) V (kN)		 Complete with drawbar eye (kg)	e1/ECE
			 R	 C			Complete with drawbar eye (kg)			
RO908H61500	6	160x100	140,0	140,0	1000	90	65,4	EG/94/20/S		
RO908H61500	6	160x100	140,0	140,0	2500	75	65,4	EG/94/20/S		
RO908H61500	6	160x100	-	140,0	1000	90	65,4	ECE 55/T		
RO908H61500	6	160x100	-	140,0	2500	75	65,4	ECE 55/T		

Bolt kit 110 mm

More information regarding our range of products can be found at www.jost-world.com

