



Montage- und Betriebsanleitung

D

Installation and operating instructions

GB

Instructions de montage et d'utilisation

F

Istruzioni per il montaggio e la manutenzione

I

Member of JOST-World

RI-BR

Fernanzeige Basisausführung – Heckanzeige

Remote indicator Basic – rear

Indicateur à distance – arrière

**Indicatore a distanza, modello base – per
parte posteriore del veicolo**

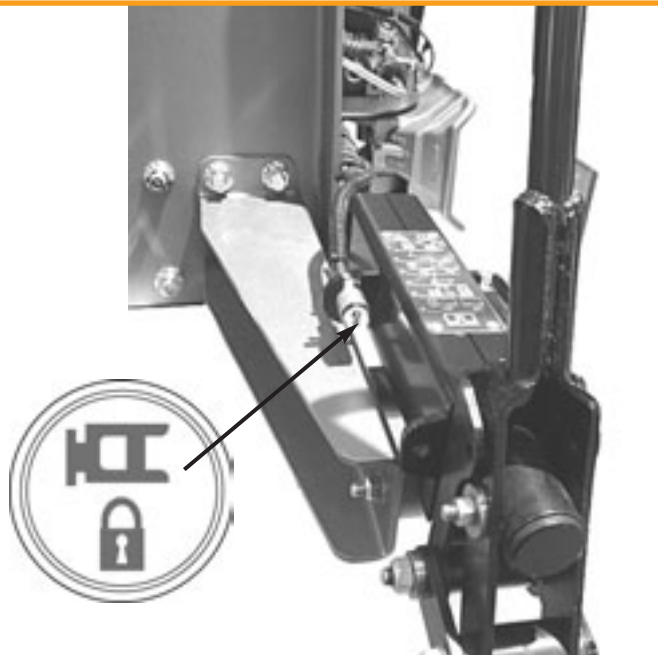

RI-BR

Remote indicator Basic – rear

for model series: RO*400, RO*430, RO*460

RO*500, RO*530, RO*560 (see table page 10)



Fitting must be carried out by an authorised workshop!

Before fitting, please read these instructions carefully!

Official note:

When fitting the retrofit kit, EC Directive 94/20, in particular Annex VII, and the relevant national regulations must be observed. The fitting and operating instructions must be kept in the vehicle.

We reserve the right to make technical alterations.

1. Installation	10 – 12
1.1 Before installation	10
1.2 Installation of the sensor	11
1.3 Connection to the vehicle electrical system	12
1.4 Function check	12
<hr/>	
2. Operation	13
2.1 Remote indicator	13
<hr/>	
3. Maintenance	14
3.1 Care	14
3.2 Inspection	14



Retrofit complete		ROE 71701	ROE 71701 M	ROE 71702	ROE 71702 M	ROE 71703	ROE 71703 M
for trailer coupling type as of T...							
T0	RO*500	-	-	-	-	X	X
T0	RO*50 and RO*50E	X	X	-	-	-	-
T0	RO*50 BNA	X	X	-	-	-	-
T1	RO*400 and RO*430	X	X	-	-	-	-
T0	RO*40E + RO*40CH	X	X	-	-	-	-
T0	RO*56E + RO*561 E	-	-	X	X	-	-
T0	RO*57 + RO*50 flex	-	-	-	-	X	X
	Mounting bracket	-	X	-	X	-	X

1.1 Before installation

The kit does not include the electric fuse!
Fuse type according to the truck manufacturer's instructions!

Note: When installing the remote indicator, please observe:

- applicable national regulations
- guidelines of the vehicle manufacturer
- the generally applicable regulations for the installation of electrical components in a truck
- possibility of axial rotation in the coupling head min. $\pm 25^\circ$

1.1.2 Interfaces

The trailer coupling must have the appropriately prepared interface for the later installation of a remote indicator or a sensor (**S1**). See Inspection.

1.1.2 Inspection of the components

- Does the retrofit kit match the trailer coupling?
 - compare the data on the type plates
 - the last digit of the article no. = techn. status (**T**, see table)
- Check the supplied components for completeness

Each retrofit kit contains:

1x sensor with indicator unit consisting of:

- 1x GREEN LED indicator (with "coupling closed" symbol)
- 1x sensor unit, single, with mounting flange (to match the coupling)
- 1x set of fastening elements, optional depending on the retrofit kit (ROE XXX M)
- 1x installation instructions

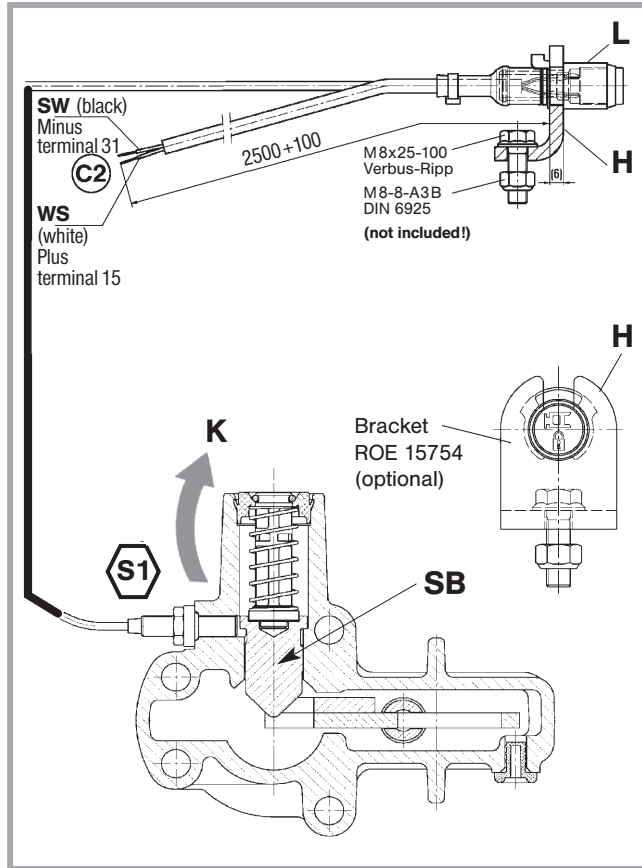

1.2 Installation of the sensor S1

1.2.1 Installation of the indicator

- Fit the bracket to the back of the vehicle in such a way that the indicator (**L**) can be cabled up to that point and that the indicator can still be seen without the operator having to enter the danger zone.
- Remove the plastic cover (**K**) at the interface to the first fuse.
- Slide the sensor (**S1**) with the fastening flange and fitted O-ring onto the interface and tighten the fastening screw with **5 Nm**.
- The sensor is already pre-set.
- Ensure axial play ($\pm 25^\circ$) of the trailer coupling.

Lay the sensor cable and the indicator with plastic clips in such a way that the cable harness is **not** scraping or kinked (do not lay too tightly, take account of axial motion of the trailer coupling).

Circuit diagram RI-BR

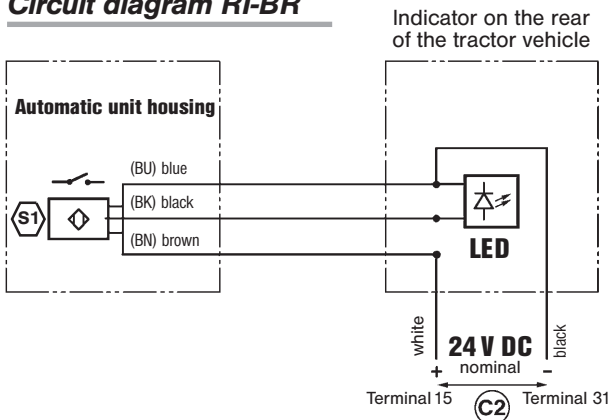

Electrical data:

Operating distance (mm): **3.0 flush**
 Operating voltage (V): **10 to 30 (PEL V)**
 Ambient temperature (°C): **-30 to +60**

1.3 Connection to the vehicle electrical system (C2) according to the circuit diagram

- Connect the black cable (earth) with **terminal 31**
- Connect the white cable (+24 Volt) with **terminal 15**
- The connection must be protected by a **2A blade-type fuse**

1.4 Function check

- The sensor is mounted on the coupling.
- Sensor **S1**
- Coupling status of the trailer coupling – open or closed.
- Indicator LED Green is mounted at the rear of the truck.
- Control voltage **24V/DC** is present when ignition is switched on:
- **When the coupling is closed and locked, the LED indicator must light up green. If not, the sensor setting may have to be readjusted as described in section 3.2**
Then carry out the function check again.

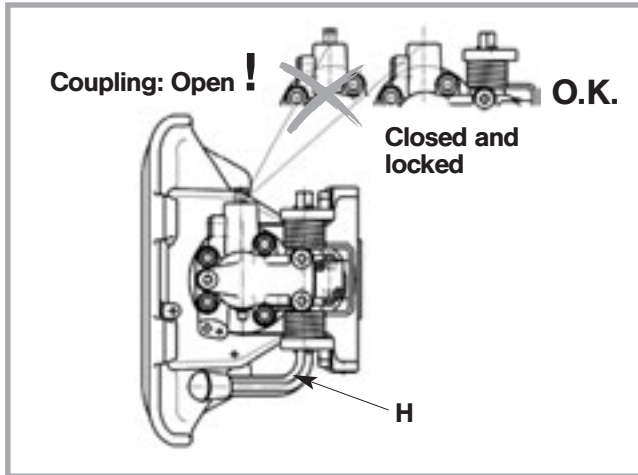

2. Operation (hitching and unhitching)

2.1 Remote indicator

- When hitching and unhitching, the applicable regulations must be observed.
- The remote indicator shows the coupling status of the trailer coupling. If the indicator is lighting green, the coupling is closed and locked
- The remote indicator **does not indicate whether the towing eye is actually coupled.**
- The remote indicator checks the coupling status with one sensor,.

Attention! If the coupling status is not clear, the driver is obliged to check it at the coupling.

Check:

After every hitching operation, the correct coupling status in accordance with the regulations must be checked.

The control pin must not project after hitching.

If the control pin is projecting, the unit is not correctly hitched.

Check by feeling when it is dark

RISK OF ACCIDENT!

The trailer may not be moved in this condition!

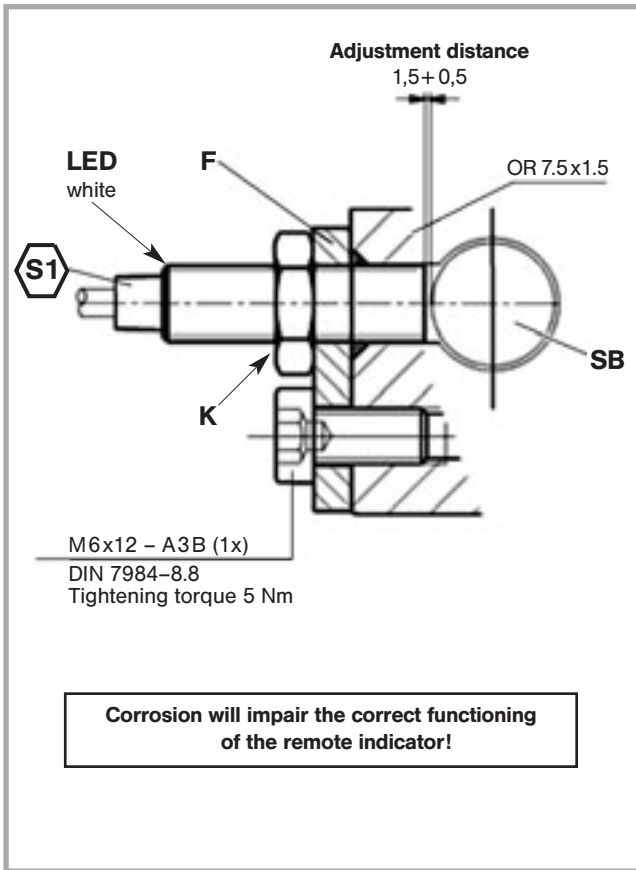

3.1 Care

- The sensor and the connection cable are maintenance-free.
- However, the cables should be checked at regular intervals for cracks, abrasion and water-tightness of the connections in order to avoid moisture penetrating the cables.

3.2 Inspection (with the coupling closed)

- The green indicator LED is lit in the rear indicator
- A control LED (white) is lit on the sensor in the area of the cable connection (when the ignition is switched on)
- If the control LED is not lighting, there are two possibilities:
- **the pre-setting is not correct**
 - 1) Release the locknut **K** on the sensor
 - 2) Turn the sensor carefully to the right until the stop, then turn the sensor back by about 1.5 rotations. Secure the setting with the locknut **K**. Maximum tightening torque **1.3 Nm**.
The LED must be lit (when the ignition is switched on).
 - 3) If not, reduce the setting until the sensor LED is lit.

- **Sensor is defective**

Attention!

The sensor must not be in contact with the component. Minimum adjustment distance: approx. 1 rotation.

- Countercheck by alteration of the mechanical switch position, e.g. opening the trailer coupling with the hand lever → the LED must go out after approx. 15 degrees hand lever angle.
- **Defective cable or sensor can only be replaced completely!**



JOST-Werke · Siemensstr. 2, D-63263 Neu-Isenburg · Telefon +49 (0) 61 02 295-0 · Fax +49 (0) 61 02 295-298 · www.jost-world.com

ZDE 199 88 263-0-00 · 07/2008