



Montage- und Betriebsanleitung

D

Installation and operating instructions

GB

Instructions de montage et d'utilisation

F

Istruzioni per il montaggio e il funzionamento

I

Member of JOST-World

Modellreihe

Series

Type

Modelli serie

RO*50 E

Vollautomatische Anhängerkupplung

Automatic Towing Hitch

Attelage de remorque entièrement automatique

Gancio di traino completamente automatico

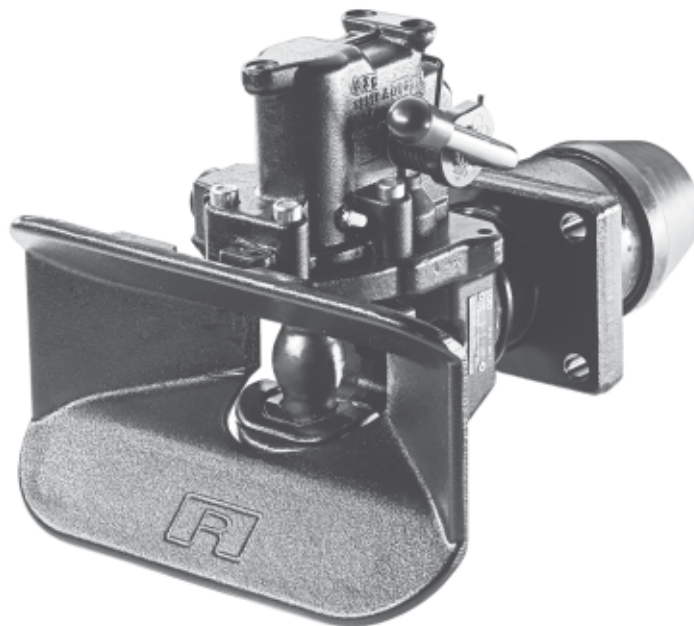

Serie RO*50 E Automatic Towing Hitch

94/20 [e1] 00-1845 Klasse C 50 X

ECE [E1] R 55-01 1845

Suitable for:

- drawbar eye 50 mm ISO 1102, DIN 74053 and EG/ECE-class D50
- Trucks class N2 and N3
- Trailers class O3 and O4

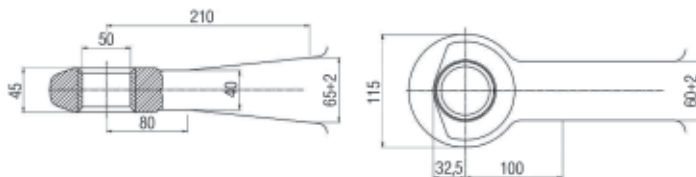

The coupling must be installed by authorised personnel!

Read these instructions carefully before fitting!

Official note

When fitting the trailer coupling the regulations for fitting mechanical fastening systems in accordance with Appendix VII ECE R 55 appendix 7 of Directive 94/20/EC and the national regulations for commercial vehicles must be observed.

Subject to technical changes without prior notice

Safety instructions

1. Mounting	16 – 18
1.1 before mounting	17
1.2 Mounting	17 – 18
2. Operation	19 – 20
2.1 Hitching	19
2.2 Closing hitch manually	20
2.3 Unhitching	20
3. Maintenance	21 – 23
3.1 Care	22
3.2 Inspection	22 – 23
Technical data	24 – 25
Upgrade kits	25





The safety instructions are summarised in a single chapter. In any situation where the user of the trailer coupling is at risk, the safety instructions are repeated in the individual sections and marked with the warning symbol shown here.

When handling trailer couplings, tractor vehicles and trailers the relevant safety regulations in the respective country must be observed (e.g. Berufsgenossenschaft in Germany). Any safety instructions in the operating manual of the tractor vehicle and the trailer remain valid and must be observed.

For operation, maintenance and assembly the safety instructions listed below must be observed. Further safety instructions are then given in the individual case which relate directly to the respective activity.

Safety instructions for operation

- The trailer coupling may only be operated by authorised persons.
- The installation and operating instructions of the respective trailer coupling retain their validity and must be observed.
- Only use the trailer coupling and the towing eye of the trailer if they are in perfect technical condition.
- Only carry out hitching / unhitching operations on firm, level ground.
- During hitching, nobody may stand between the tractor vehicle and the trailer.
- After every hitching operation the correct locked status of the trailer coupling must be checked by means of the control pin or the remote indicator. Only drive the rig in the correctly locked status.
- The remote indicator does not exempt the driver from the obligation to check before driving off subject to StVZO (Regulations Authorising the Use of Vehicles for Road Traffic). Before driving off, among other things, the coupling status of the mechanical connection device for the tractor vehicle and the trailer must be checked.

Safety instructions for maintenance

- For maintenance work, only use the prescribed lubricants.
- Maintenance work may only be carried out by qualified personnel.

Safety instructions for installation

- Installation may only be carried out by authorised workshops.
- Installation must be carried out in compliance with the relevant accident prevention regulations and the technical regulations for mechanical equipment.
- Only original components may be used.
- Instructions and installation guidelines of the vehicle manufacturer must be observed, e.g. type of fastening, clearances etc.
- All screwed connections must be tightened with the prescribed tightening torque.
- Work may only be carried out on the trailer coupling when it is closed.

Risk of injuries!

The installation of the trailer coupling on the tractor vehicle must be carried out in accordance with Annex VII of EC Directive 94/20 and must be checked accordingly. As applicable, the relevant licensing regulations in the respective country must be observed.

§§ 19, 20 and 21 StVZO apply in Germany. The mechanical remote control and the mechanical remote indicator are equipment with safety components. This is why the installation must be documented.



The trailer coupling, the remote control and the remote indicator are connection devices which require model approval and are subject to the highest safety requirements.

Alterations of any kind shall cause the warranty to lapse and invalidate the model approval, which in turn invalidates the vehicle operation permit. In order to avoid unauthorised opening of the lock, a padlock should be used on the master cylinder.

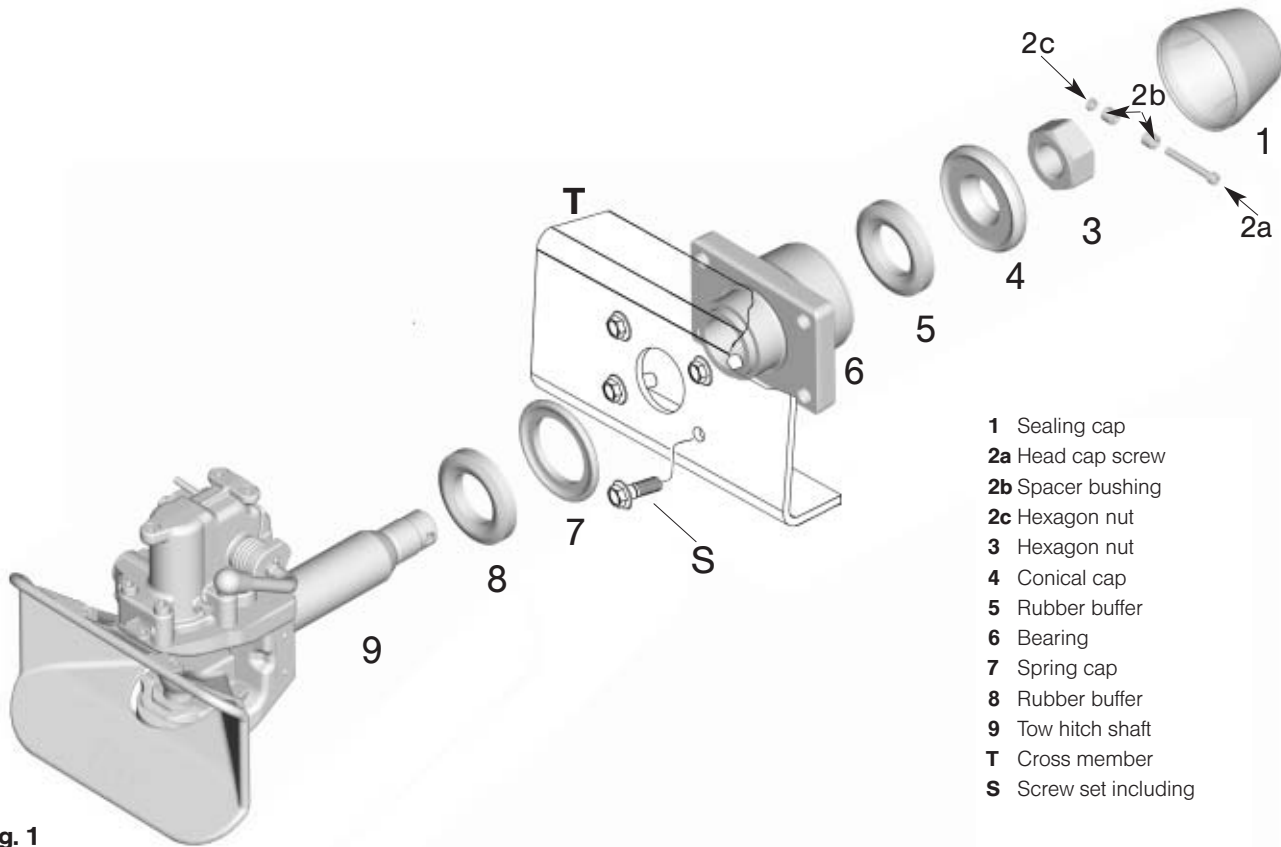

- 1** Sealing cap
- 2a** Head cap screw
- 2b** Spacer bushing
- 2c** Hexagon nut
- 3** Hexagon nut
- 4** Conical cap
- 5** Rubber buffer
- 6** Bearing
- 7** Spring cap
- 8** Rubber buffer
- 9** Tow hitch shaft
- T** Cross member
- S** Screw set including

Fig. 1

1.1 Before Mounting

Note: Please comply with following when fitting hitch:

- applicable national regulations
- vehicle manufacturers specifications
- clearance for axial rotation of coupling head of at least $\pm 25^\circ$ min.

Fig. 1:

- Unscrew **3**
- Remove **4, 5, 6** and **7** (**8** remain on **9**)

Note:

- **1** and **2** are in the equipment pack
Do not remove the copper grease and the special grease from the parts.

1.2 Mounting

- Install the bearing (**7**) onto the inner side of the cross member
- Secure with 4 hexagon bolts with flange M 20x1.5, grade 10.9 and 4 hexagon bolts with flange, grade 10.
Bolts, nuts and torque to be chosen, see table (Order no. 71122)
Note: Observe manufactures' instructions in case different bolts and nuts are recommended!

ATTENTION:

Mount bolt heads on the side directed towards the jaw (outside the cross member) to avoid impairing movability of the hitch (see Fig. 2)

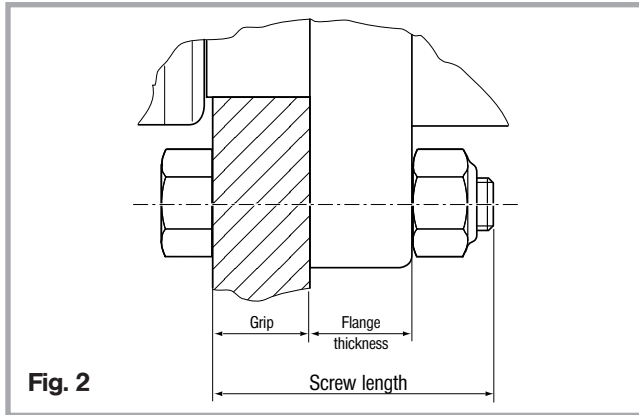

Fig. 2

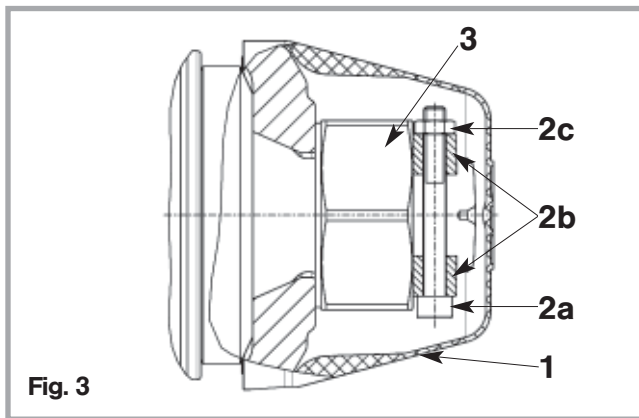

Fig. 3

Grip (thickness) of cross member (s. fig. 2)

Central-axle-trailer:	11 – 35 mm
Drawbar trailer:	max. 35 mm

Torque of bolts on the bearing

Size of hitch	Size of bolts	Grade	Tightening torque ¹⁾ (Nm)	ROCKINGER set of bolts part no.
61	M 20	10.9	580	71122

¹⁾ use a torque meter

- Insert spring cap (7) (concave side facing 8) onto 6
- Shaft of hitch 9 with 8 into 6 (do not remove grease, if necessary regrease with EP3 grease)
- 5 and 4 (like 7) onto 9
- Tighten 3, **tightening torque 750 Nm**
- Locate 1 x 2b onto 2a
- Slide 2a and 2b through the bore
- Locate 1 x 2b onto 2a and tighten with 2c: **tightening torque 32 Nm**
- Fit the sealing cap (1) to protect against corrosion.

Note:

Before painting, it is essential to close hitch and grease or **cover** coupling pin.

After painting clean and regrease the coupling pin.



Tractor unit with drawbar trailer

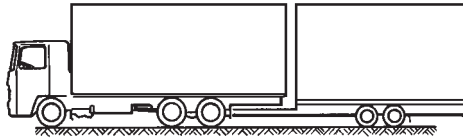

Tractor unit with rigid trailer

Fig. 4



Fig. 5

2.1 Hitching (Fig. 4)



Note: The relevant national regulations (f.e. safety-at-work) must be observed when hitching and unhitching.

No one must stand between the vehicles!

- To engage, press hand lever upwards until it engages
- Check whether funnel is **locked**.
- Position drawbar eye in centre of funnel
- **Disengage brake on front axle** of turntable drawbar trailer
- Set drawbar eye to height of coupling point (centre of funnel).
- Slowly reverse prime mover

When hitching to a central-axle trailer (see fig. 4):

- Reverse prime mover very slowly
- The drawbar eye must be inserted into the middle of the funnel.

Otherwise the jaw, the drawbar eye or the drawbar support legs might be damaged.



Check: After each hitching procedure, it is essential to check that the hitch is correctly closed and locked. The lock-control pin must not protrude out of its guide after hitching (see fig. 5) If the lock-control pin protrudes from its guide (in the dark detectable by touching it), the hitching procedure has been carried out incorrectly and there is the **risk of an accident!**

Driving a trailer in that condition is not allowed.

If not correctly coupled:

- move the prime mover forward (approximately 1 m)
- check again

In-cab status indicator upgrade kit available for retrofitting.

Fig. 6

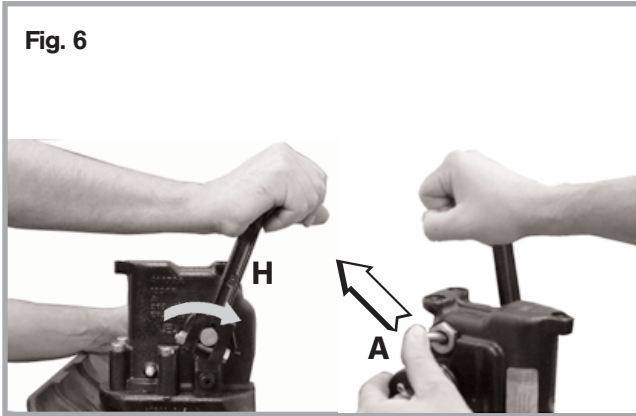

2.2 Closing hitch manually (see fig. 6)

(e.g. for tow-rope):

- Press hand lever (**H**) upwards until its end position and hold it; press at the same time the stop lever (**A**) to its end position.
- Reverse hand lever to the closed position
- or:
- Close the release lever using a suitable tool



**Warning: Don't put your hands into the jaw / bolt area!
Danger of injury due to automatically closing!**

2.3 Unhitching

Observe the relevant national regulations (f.e. safety-at-work) when hitching and unhitching!

- Secure trailer to prevent it from rolling away.
- In case of central axle trailer wind down support leg(s)
- Disconnect supply lines to trailer.
- Push hand lever upwards until it engages in its upper position (hitch is open)
- In the event of seizing between the hitch and trailer assist the unhitching process by moving the vehicle backwards and forwards **or** by using the air suspension system.
- unhitch prime mover.

Note:

When driving without a trailer, keep the hitch closed to protect the ingress of dirt of the lower bush.

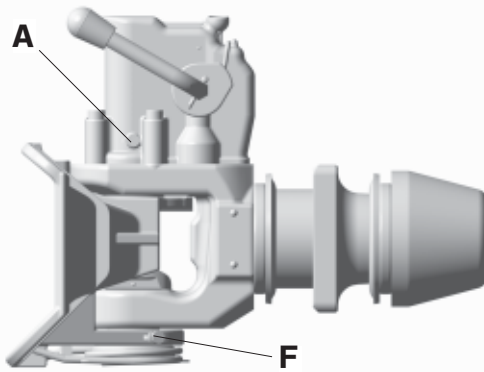

Fig. 7

3.1 Care

Before starting maintenance work on the hitch ensure that hitch is closed. **Risk of Injuries!** (see para. 2.2)

- Lubricate coupling pin, support ring and drawbar eye with heavy-duty grease (EP3) which is waterproof if possible before first use and after extended period in use.
- Under harsh operating conditions or severe exposure to dirt or water regrease automatic unit **(A) when coupling is open** (see fig. 7):
 - use multi-purpose grease NLGI 2
 - intervals: 6 months or 50,000 km
- Lubricate lower funnel bearing **(F** see fig. 7) with EP3 grease.

Note: Close coupling before cleaning with high-pressure washers (see para. 2.2).

- **After cleaning**, relubricate coupling pin and support ring with EP3 grease.

Please note following when carrying out repairs on coupling (e.g. changing coupling pin):

- Remove as much of old grease as possible.
- Relubricate with multi-purpose grease (NLGI 2; temperature range –40° bis 120°C)

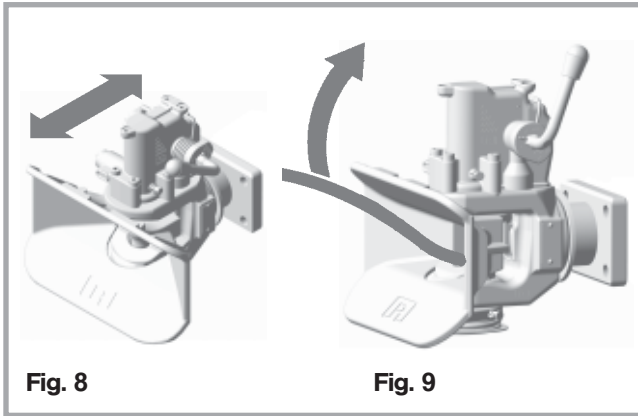

Fig. 8

Fig. 9

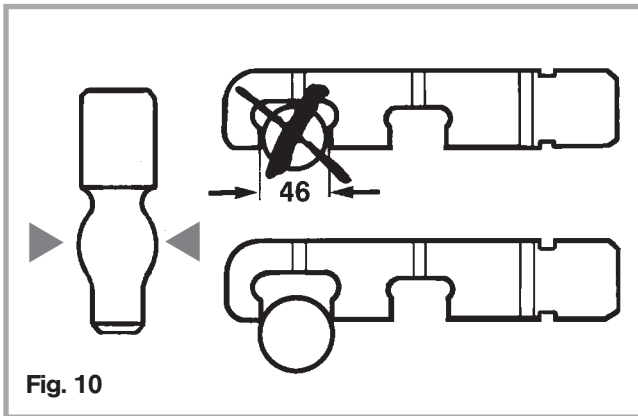

Fig. 10

3.2 Inspection

Bearing:

– Longitudinal play

- Grip coupling head (not jaw funnel) with both hands when uncoupled and move vigorously in longitudinal direction (see fig. 8): **No longitudinal play is allowed.**

– Vertical play

- Open hitch.
- Move coupling head up and down with appropriate tool (see fig. 9): Vertical play may **not exceed 3 mm** measured at coupling head (centre axis of coupling pin).

Coupling pin:

Check wear using ROCKINGER reference gauge (order no. 57122) (see Fig. 10):

Coupling pin may be used until diameter of crowned section has worn to less than **46 mm**, after which it must be replaced.

Vertical play in coupling pin (see fig. 11; page 26) may **not exceed 2 mm**.

Fig. 11

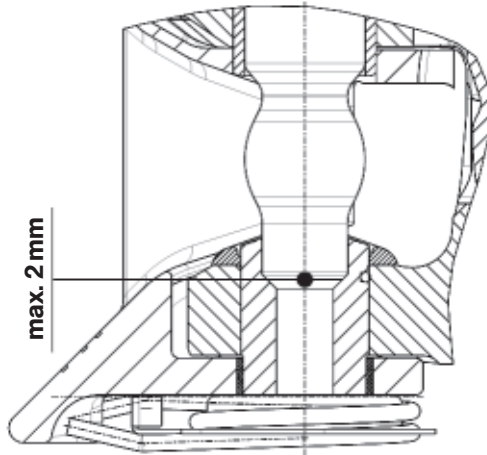

Lower bush:

Check wear using ROCKINGER reference gauge (order no. 57334).
Max. admissible internal diameter of lower bush is **35.9 mm**.



Passage below pin must be free.

In case of nonobservance there is a risk of accident,
because the coupling bolt can not come into its secured
position.

Please consult repair leaflet (available on request) for details of repla-
cing.

Fig. 12

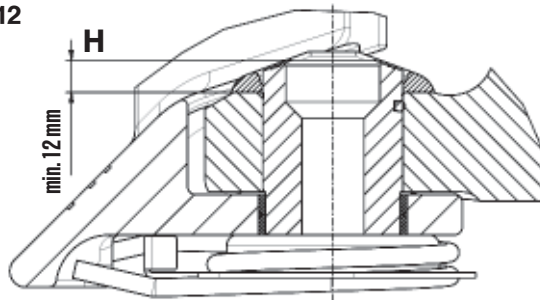

Support ring:

Support ring for drawbar eye (**H**) must be replaced if drawbar eye
could touch lower bush because of wear (see fig. 12).



**Lower bush must not be damaged under any circum-
stances as this will impair closure of coupling.**

Take care to prevent risk of accident!

Always grease support ring to reduce wear (please consult repair
leaflet, available on request, for details of replacing).

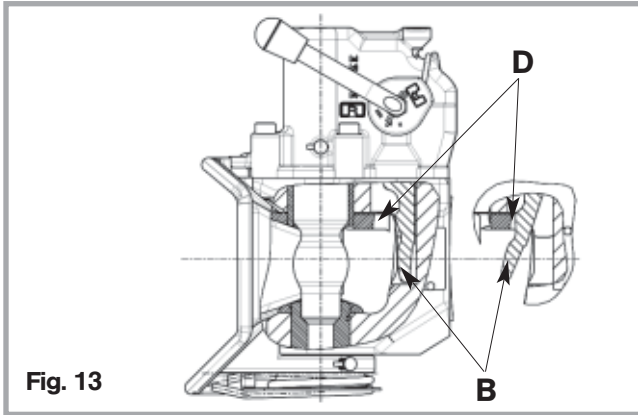

Fig. 13

Check lock of the funnel:

Note: The funnel must be locked in its central position when coupling is opened to be prepared for coupling on!

- Push the funnel sideways
- Move handlever in locking direction (up)
- Release funnel
- The funnel must swing back in central position and be locked again (Release lever **(B)** locks funnel over groove **(D)**) (see fig. 13)
- If not, justify the central position by the lower unit as below.

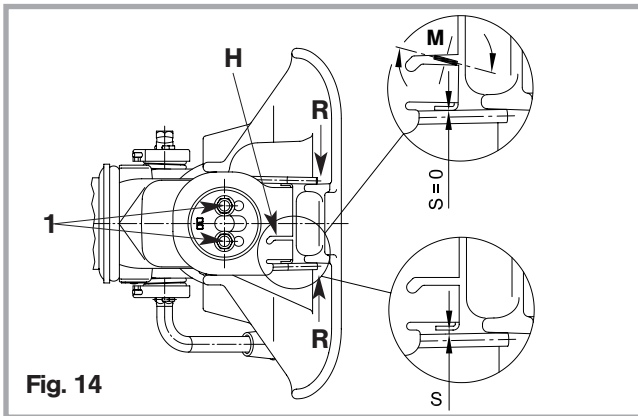
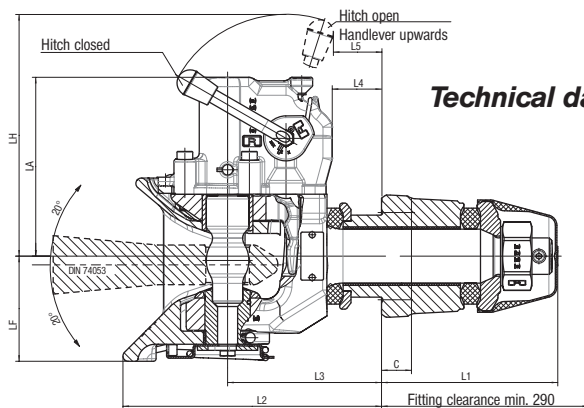

Fig. 14

Adjustment:

- Loosen screws **(1)** and bring the funnel into the central position:
- Open coupling: Funnel lock should be inserted
- Tighten screws **(17)** – **Tightening torque 85 Nm.**
- Both ends of torsion spring sides **(R)** must lie slack free **(S)** against the rib of the funnel. Between the spring holder **(H)** and the lay-on points of the torsion springs should also be no gap.
- In case there is a gap you can close it very easily by bending the spring holder with a screwdriver **(M)** (see fig. **(S = 0)**).





Technical data

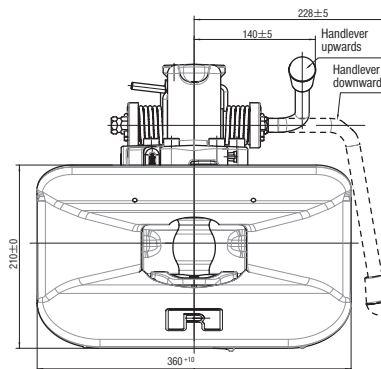

Serie RO*50 E

94/20 e1 00-1845
 Class C 50 X
 ECE R 55-01
 E1 1845

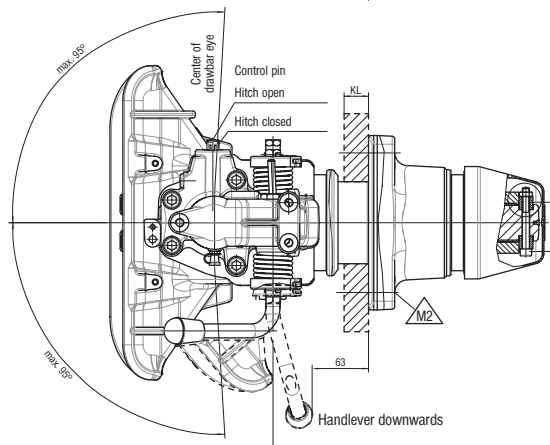

Flange size to 94/20/EC

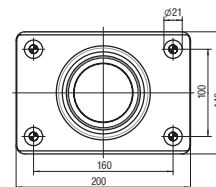

Size	a (mm)	b (mm)	c (mm)	d (mm)	e (mm)	f (mm)
61	160	100	200	140	21	94

Size Var.	L1 (mm)	L2 (mm)	L3 (mm)	L4 (mm)	L5 (mm)	Lm (mm)	C (mm)	KL ¹⁾ (mm)	KL ²⁾ (mm)
61	201,5	296,5	176,5	56,5	55,5	230	30	35	11-35

¹⁾ drawbar trailer ²⁾ rigid trailer

									e1		
			(mm)	D (kN)	Dc (kN) ¹		S (kg) ²	V (kN)	kg		
RO510A61000	A	6	160x100	285	140		1000	90	50	00-1845	
RO510A61000	A	6	160x100	285	140		2500	60	50	00-1845	
RO510B61000	B	6	160x100	285	140		1000	90	50,5	00-1845	
RO510B61000	B	6	160x100	285	140		2500	60	50,5	00-1845	
RO510A61200	A	6	160x100	285	140		1000	90	51	00-1845	X
RO510A61200	A	6	160x100	285	140		2500	60	51	00-1845	X
RO510A61400	A	6	160x100	285	140		1000	90	56	00-1845	X
RO510A61400	A	6	160x100	285	140		2500	60	56	00-1845	X

¹ Calculation see catalogue or Internet: <http://www.jost-world.com>

² When using a central-axle trailer, the vertical load should amount to at least 4% of the trailer weight, in order to prevent increased wear caused by bouncing of the drawbar eye

Upgrade kits

RO*50 E

Upgrade kit remote operation* part no.

Mechanical remote operation	
power assistent opening	ROE 71599FA4H
Pneumatic remote operation	
power assistent opening and closing	ROE 71594

***Repair instructions and parts list to be obtained upon request!**

Upgrade kit remote control* part no.

Mechanical remote indicator	ROE 71575
Elektrical remote indicator; in-cab status indicator	ROE 71654
Elektrical remote indicator; rear indicator	ROE 71701
Elektronical remote indicator; in-cab status indicator	ROE 71546

***Repair instructions and parts list to be obtained upon request!**



JOST-Werke · Siemensstr. 2, D-63263 Neu-Isenburg · Telefon +49(0)61 02 2 95 -0 · Fax +49(0)61 02 2 95 -298 · www.jost-world.com
ZDE 199 88 225-00-020 · 12/2008