



**ROCKINGER**

® *Montage- und Betriebsanleitung*

*Installation and operating instructions*

*Instructions de montage et d'utilisation*

*Monterings- och driftanvisning*

*Monterings- og bruksanvisning*

**D**

**GB**

**F**

**S**

**N**

*Member of JOST-World*

**Modellreihe**

**Series**

**Type**

**Modellserie**

**Modellserie**

**RO\*CM 75**

**Anhängebock**

**Drawbeam**

**Traverse**

**Dragbalken**

**Trekkebjelke**

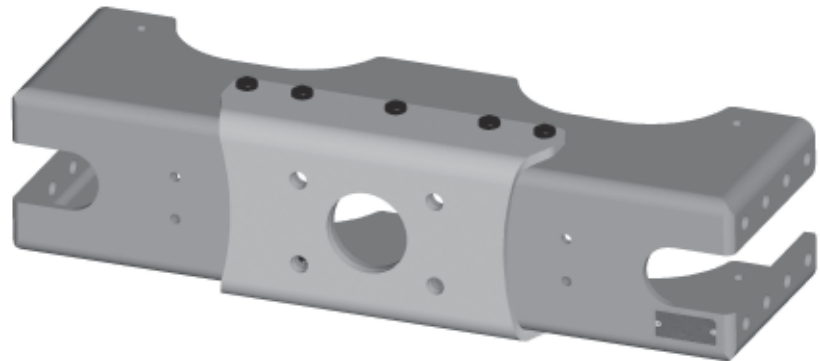

## Series RO\*CM 75

### Drawbeam

94/20 Class F

e1 00-1615

ECE R 55 01 Class F

E1 55 R-01 1615



The installation and operating instructions must be kept in the vehicle!



The crossbar and side plates must be fitted by qualified personnel!

Read these instructions carefully before fitting!

### Official note

When fitting the drawbeam the EC directive 94/20, in particular annex VII, and the standards ISO 11406 and ISO 11407 as well as the guidelines of the vehicle manufacturer and the relevant national regulations must be observed.

Subject to technical changes without prior notice.

<b>1. General</b>	<b>26 – 27</b>
<b>1.1 Installation variations</b>	<b>27</b>
<b>1.2 General instructions</b>	<b>27</b>
<hr/>	
<b>2. Correct usage</b>	<b>28</b>
<hr/>	
<b>3. Installation</b>	<b>29 – 44</b>
<b>3.1 Before installation</b>	<b>29 – 30</b>
<b>3.2 Central installation</b>	<b>31 – 34</b>
<b>3.2.1 Installation</b>	<b>31 – 32</b>
<b>3.2.2 Technical data</b>	<b>33 – 34</b>
<b>3.3 Half-lowered installation</b>	<b>35 – 38</b>
<b>3.3.1 Technical data</b>	<b>35 – 36</b>
<b>3.3.2 Installation</b>	<b>37 – 38</b>
<b>3.4 Lowered installation</b>	<b>39 – 44</b>
<b>3.4.1 Installation</b>	<b>39 – 44</b>
<hr/>	
<b>4. Maintenance / inspection / documentation</b>	<b>45 – 46</b>

## 1.1 Installation variations

Fig. 1

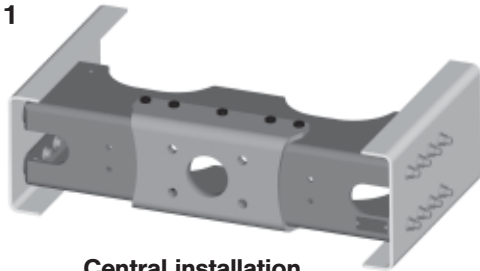

**Central installation**  
(end crossbar)

Fig. 2

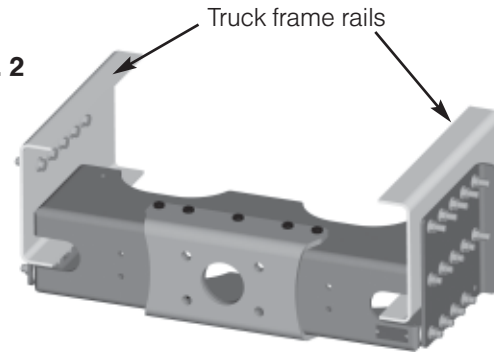

**Half-lowered installation**

Fig. 3

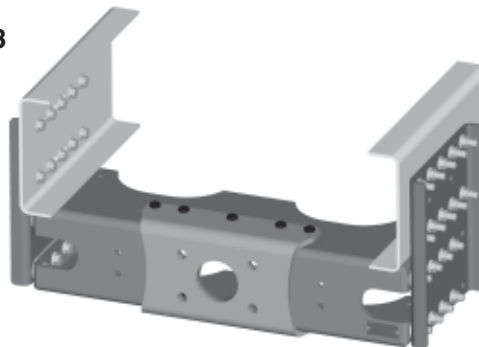

**Lowered installation**

## 1.2 General instructions

The drawbeam RO★CM75 – hereinafter referred to as crossbar and side plates – is designed for vehicles with a total weight of at least 10 tonnes. The crossbar can be installed centrally in the truck frame rail (central installation; see Fig. 1) or in a half-lowered (half-lowered installation; see Fig. 2) or fully lowered (lowered installation; see Fig. 3) position with Rockinger side plates.

Alongside the installation instructions (see points 2 to 4) the instructions of the vehicle manufacturer, including any instructions for frame reinforcement, must be observed.

Fitting and maintenance must be carried out by **qualified personnel**.

Give all of the instructions and guidelines to the customer. These must be kept in the vehicle for the purposes of maintenance, care and documentation.

For the fitting of a connection facility in the crossbar, the conditions for correct usage (see section 2) must be observed.

Before starting fitting work, identify all parts and make sure they are complete.



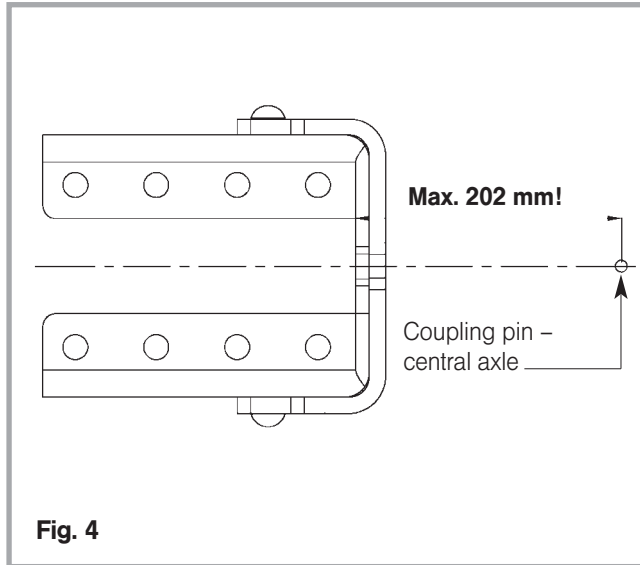

When fitting and operating a **type-approved** trailer hitch **suitable for the application area** (pursuant to 94/20/EC) with a maximum effective length of 202 mm, make sure that the **permissible load values – D-value, Dc value, V-value and vertical load –** of the crossbar are **NOT exceeded**.

(for more information see:

[www.jost-world.com/content/de/produkte/ROCKINGER/rockinger-strasse-produkt-katalog.html](http://www.jost-world.com/content/de/produkte/ROCKINGER/rockinger-strasse-produkt-katalog.html))

This must be taken into account for the combination of tractor vehicle and trailer.

The permissible values are listed in the "Technical Data" of the respective installation variation and on the type plate.

The trailer hitch must be fitted in accordance with the installation and operation instructions of the hitch manufacturer.

If a hitch with approval for **central axle trailer operation** is used, **the maximum distance of the coupling pin from the inner surface of the crossbar may not exceed 202 mm** (see fig. 4).

Maintenance must be carried out at regular intervals in accordance with section 4.

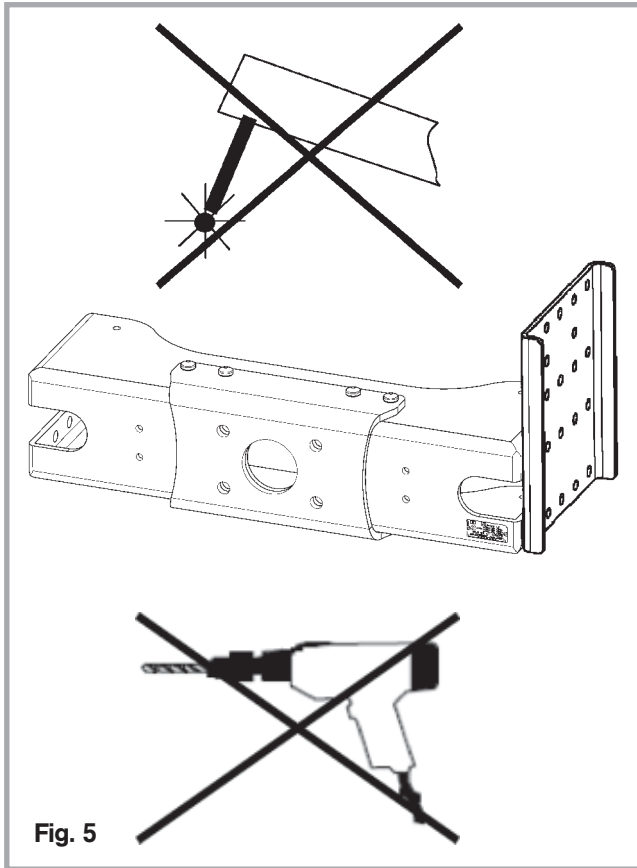

Fig. 5

### 3.1 Before installation

**The installation instructions of the vehicle manufacturer must be observed.**

Crossbars and side plates are type-approved parts. For this reason no subsequent alterations may be made to them.

The crossbar may only be screwed on using the permitted screws.

**Welding is NOT permitted!**

The crossbar already has all of the borings required for the fitting of the crossbar and accessories.

**The drilling of further holes is NOT permitted!**

The crossbar and the side plates are provided with surface protection in the factory.

**Further coating of the screwed surfaces** (= contact areas with the vehicle frame rail or between side plates and crossbar) **is NOT permitted!**

It must also be ensured that the screwed surfaces are **clean and free of grease.**

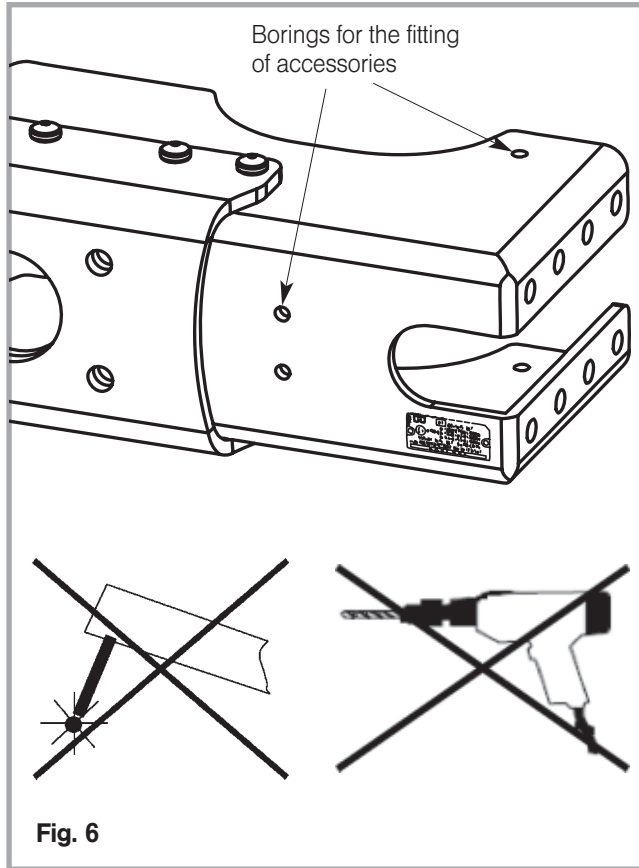

Fig. 6

The specification of the tightening torque **M1** refers to the nut.

The ROCKINGER nuts and bolts are already coated with a lubricant to reduce friction.

**Additional lubrication (e.g. oil) is NOT permitted!**

For the fitting of accessories (e.g. brackets for power and air connections) the borings provided must be used (see Fig. 6).

**Additional borings or welds are NOT permitted!**

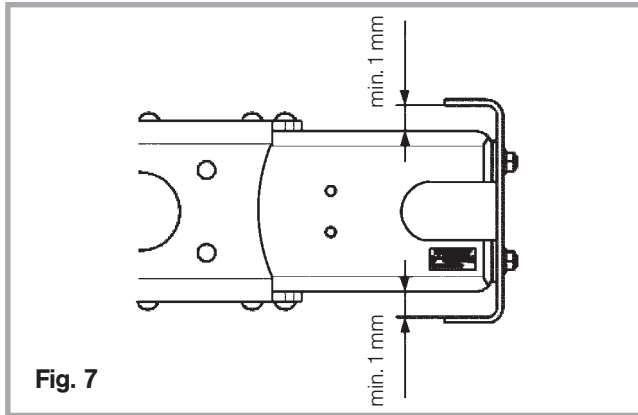

Fig. 7

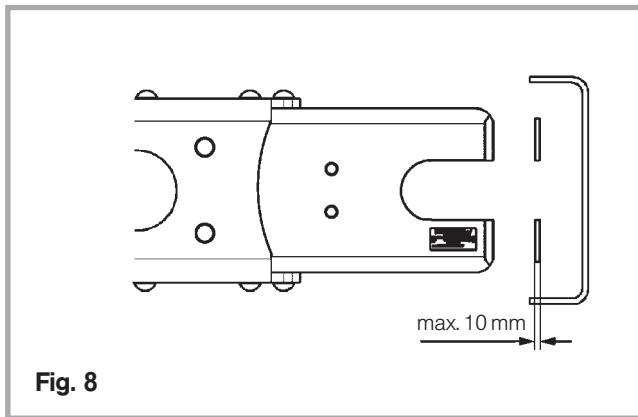

Fig. 8

### 3.2 Central installation (end crossbar)

#### 3.2.1 Installation

The instructions under 3.1 "Before installation" must be observed.

The crossbar must be fitted in such a way that there is **NO contact with the flanges** of the vehicle frame rail (see Fig. 7).

**A minimum distance of 1 mm must be maintained!**

The crossbar must be fitted at the centre between the frame rails. If distance washers are required to adjust the length, they must be fitted on both sides.

Distances washers are available in thickness of 1, 2, 4, 6, 8 and 10 mm **A maximum of 10 mm on each side is permissible** (see Fig. 8). However, a **maximum of two washers per row of screws** may be fitted.

If possible, the use of distance washers should be avoided.

The fastening holes in the vehicle frame are drilled with a  $\varnothing 17$  drill bit. The crossbar can be used as a drilling template.

**The crossbar may NOT be held in place for boring by welding!**

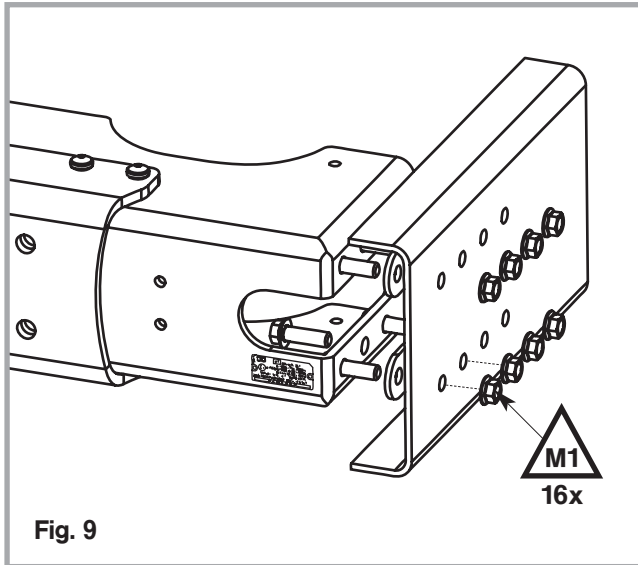

The **ROCKINGER fastening set must be used** to fasten the crossbar to the vehicle rail (see Table 1).

Quantity	Part	Surface	Tightening torque
16	Flange locking bolt M16 x 1.5; Strength class 10.9	Dacromet + TTF	 <b>380 Nm</b>
	Flange locking nut M16 x 1.5; Strength class 10		

Table 1: Tightening torque M1; number of nuts and bolts required (cross bar bolt set, ROE71579)

All **16 nuts and bolts** must be fitted as illustrated in Fig. 9.

**No washers may be used for the nut and bolt as this will disable the locking function.**

**The tightening torque M1** (see Table 1) **must be applied with the aid of a torque wrench and inspected and documented on first fitting and on inspection after 5000 km** (see Section 4).



## 3.2.2 Technical data

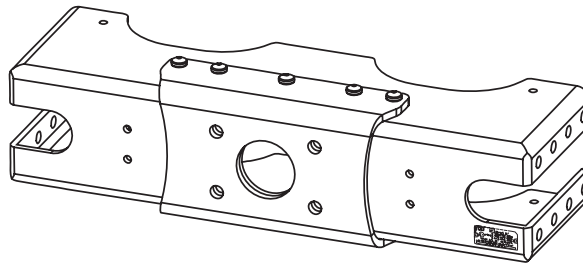
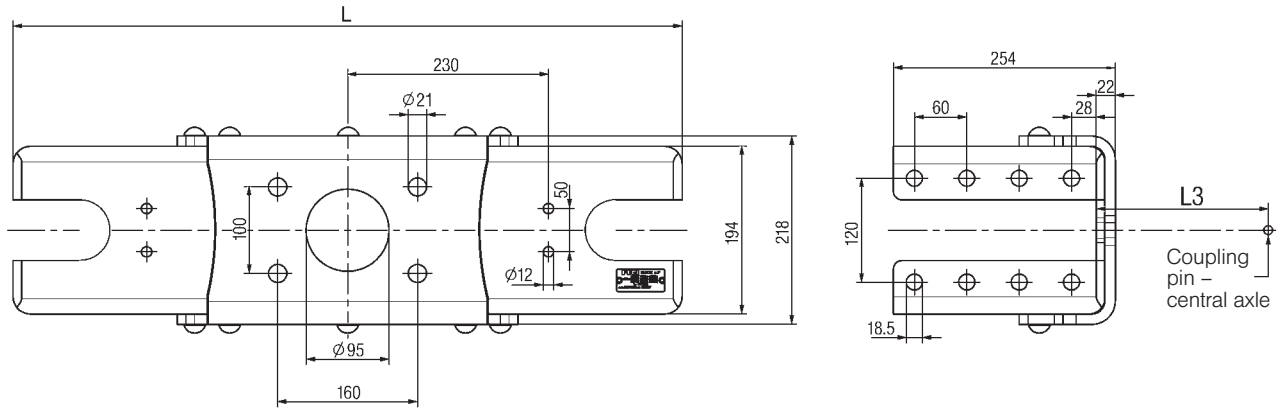



**Technical data crossbar**

Article number	Code	Crossbar-length L (mm)	Type of approval	Class	Type	Approval mark	D value (kN)	Dc value (kN)	V value (kN)	Perm. stat. vertical load (kg)	L3 max. (mm)	Calculated weight (kg)
ROCM75 N728 A02	10	728	94/20/EG	F	RO★CM75	e1 00-1615	200	130	75	1000	202	46,4
ROCM75 N742 A02	11	742										51,7
ROCM75 N752 A02	12	752										48,0
ROCM75 N756 A02	13	756										48,1
ROCM75 N762 A02	14	762										48,4
ROCM75 N766 A02	15	766										48,5
ROCM75 N770 A02	16	770										48,7
ROCM75 N784 A02	17	784										49,2
ROCM75 N834 A02	18	834										51,1
ROCM75 N850 A02	19	850										51,7

### Side plate SPS

Article no.: ROE 75031

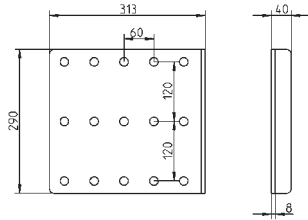

### Side plate SPU (S)

Article no.: ROE 75035 X = 60 / ROE 75065 X = 50

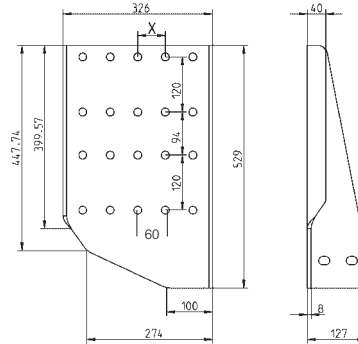

### Side plate SPM

Article no.: ROE 75037

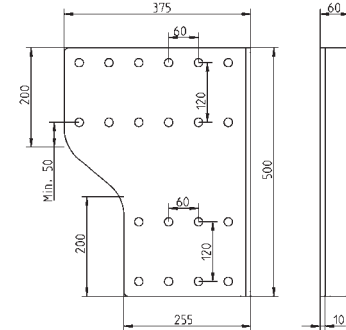

### Side plate SPH

Article no.: ROE 75032 X = 60 / ROE 75062 X = 50

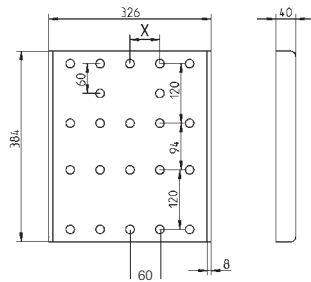

### Side plate SPU

Article no.: ROE 75034 X = 60 / ROE 75064 X = 50

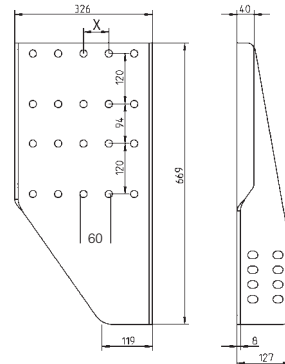

### Side plate SPL

Article no.: ROE 75033

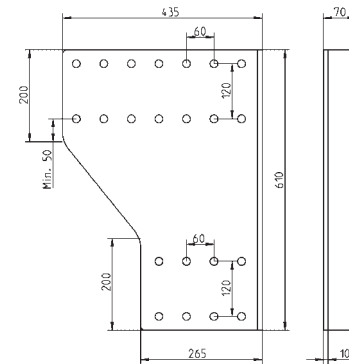

## Side plate SP (MAN)

Article no.: ROE 75036

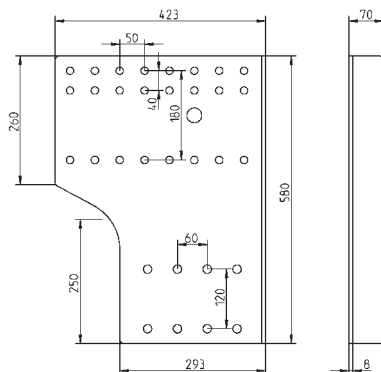

**Fig. 10**

## Side plate SPV

Article no.: ROE 75038

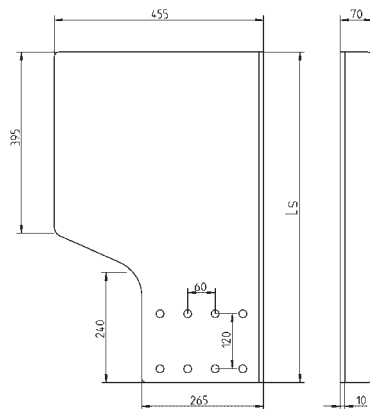

**Fig. 11**

## 3.3.1 Technical data

Side plates			
Article number Side plate	Designation (code)	Height H (mm)	Weight Pair (kg)
ROE 75031	SPS	205	12
ROE 75032	SPH	299	17,6
ROE 75033	SPL	520	37,8
ROE 75034	SPU	299	30,6
ROE 75035	SPU(S)	299	25,6
ROE 75036	SP (MAN)	490	29,5
ROE 75037	SPM	410	27,6
ROE 75038	SPV	510 to 630	Up to 49

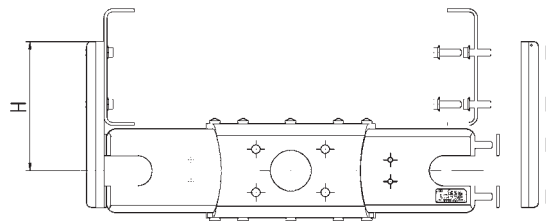

**Fig. 11a**

Fig. 12

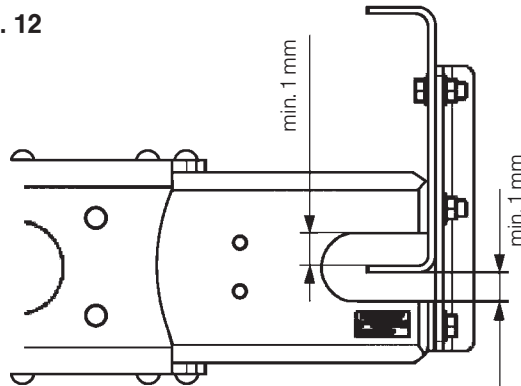
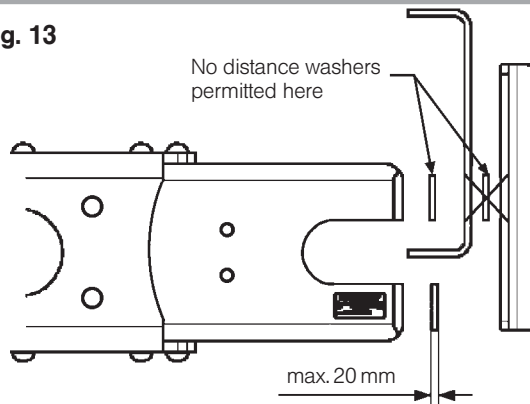

Fig. 13



## 3.3 Half-lowered installation

### 3.3.2 Installation

The instructions under 3.1 "Before installation" must be observed.

The crossbar must be fitted in such a way that there is **NO contact with the flanges** of the vehicle frame rail (see Fig. 12).

**A minimum distance of 1 mm must be maintained.**

As far as possible, the flange of the vehicle frame rail should be fitted at the centre of the crossbar.

The crossbar must be fitted at the centre between the frame rails. If distance washers are required to adjust the length, they must be fitted on both sides.

Distance washers are available in thickness of 1, 2, 4, 6, 8 and 10 mm.

**A maximum of 20 mm on each side is permissible** (see Fig. 13). However, **a maximum of 2 washers per row of screws** may be fitted.

If possible, the use of distance washers should be avoided.

**Distance washers are NOT permitted between the side plate and the frame rail and between the crossbar and the frame rail** (see Fig. 13).

The fastening holes in the vehicle frame are drilled with a  $\varnothing 17$  drill bit. The crossbar can be used as a drilling template.

**The crossbar may NOT be held in place for boring by welding.**

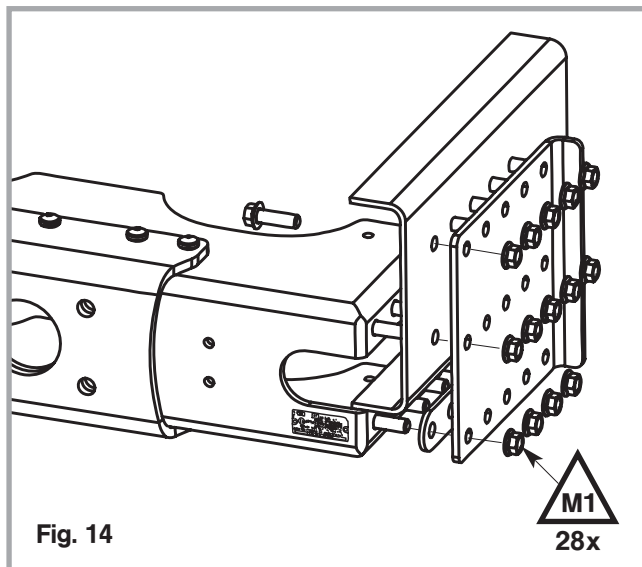

The **ROCKINGER fastening sets must be used** to fasten the crossbar and the side plates (see Table 2).

Quantity	Part	Surface	Tightening torque
28	Flange locking bolt M16 x 1.5; Strength class 10.9	Dacromet + TTF	 <b>380 Nm</b>
28	Flange locking nut M16 x 1.5; Strength class 10	Dacromet + TTF	

Table 2: Tightening torque M1; number of nuts and bolts required (screw set for side plates SPS ROE71580)

All **28 nuts and bolts** must be fitted (14 on each side) as illustrated in Fig. 14.

**No washers may be used for the nut and bolt as this will disable the locking function.**

**The tightening torque M1** (see Table 2) **must be applied with the aid of a torque wrench and inspected and documented on first fitting and on inspection after 5000 km** (see Section 4).

Fig. 15

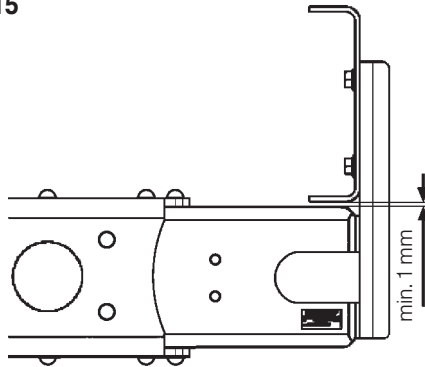
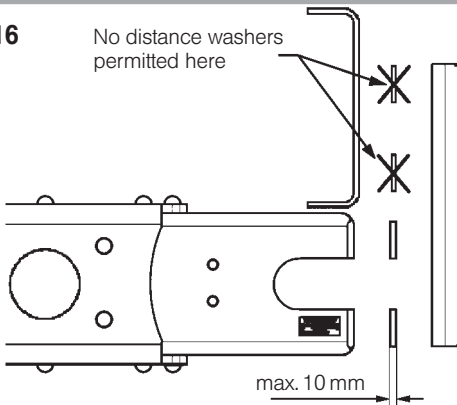

Fig. 16



## 3.4 Lowered installation

### 3.4.1 Installation

The instructions under 3.1 "Before installation" must be observed.

The crossbar must be fitted in such a way that there is **NO contact with the flanges** of the vehicle frame rail (see Fig. 15).

**A minimum distance of 1 mm must be maintained.**

The crossbar must be fitted at the centre between the frame rails. If distance washers are required to adjust the length, they must be fitted on both sides.

Distances washers are available in thickness of 1, 2, 4, 6 8 and 10 mm.

**A maximum of 10 mm on each side is permissible** (see Fig. 16). However, a **maximum of 2 washers per row of screws** may be fitted.

If possible, the use of distance washers should be avoided.

**Distance washers are NOT permitted between the side plate and the frame rail and between the crossbar and the frame rail** (see Fig. 16).

The fastening holes in the vehicle frame are drilled with a  $\varnothing 17$  drill bit. The crossbar can be used as a drilling template.

**The crossbar may NOT be held in place for boring by welding.**

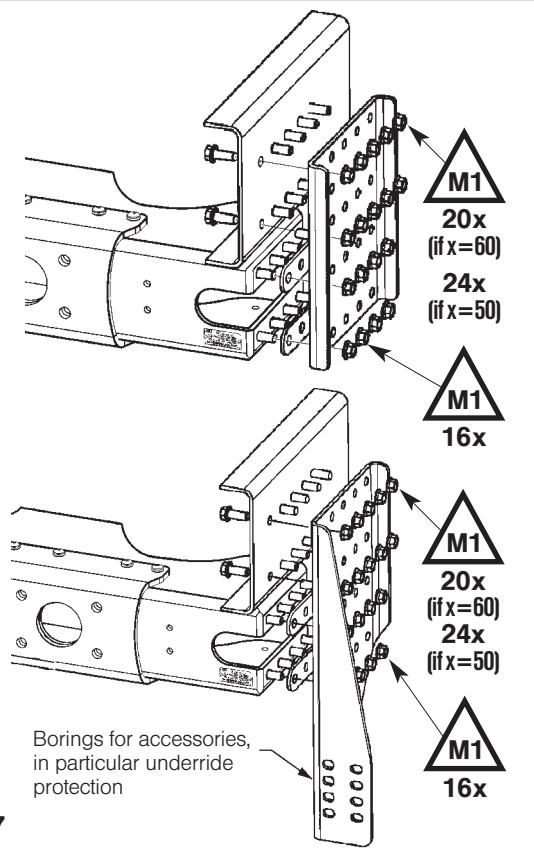

Fig. 17

### a) Installation of side plates SPH, SPU and SPU(S)

The **ROCKINGER fastening sets must be used** to fasten the crossbar and the side plates (see Table 3).

Quantity	Part	Surface	Tightening torque
<b>36</b> (if x=60)	Flange locking bolt M16 x 1.5;	Dacromet + TTF	 <b>380 Nm</b>
<b>40</b> (if x=50)	Strength class 10.9		
<b>36</b> (if x=60)	Flange locking nut M16 x 1.5;	Dacromet + TTF	
<b>40</b> (if x=50)	Strength class 10		

Table 3: Tightening torque M1; number of nuts and bolts required (screw set for side plates SPH, SPU/S ROE71620, with X=50 mm, see page 35, ROE 71621)

All **36 nuts and bolts** must be fitted (18 on each side if x = 60 mm) as illustrated in Fig. 17.

All **40 nuts and bolts** must be fitted (20 on each side if x = 50 mm) as illustrated in Fig. 17.

**No washers may be used for the nut and bolt as this will disable the locking function.**

**The tightening torque M1 (see Table 3) must be applied with the aid of a torque wrench and inspected and documented on first fitting and on inspection after 5000 km (see Section 4).**

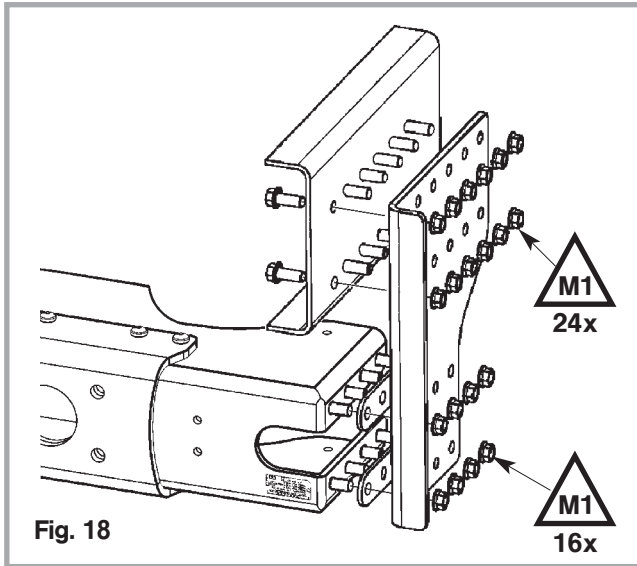

#### b) Installation of side plates SPM

The **ROCKINGER fastening sets must be used** to fasten the crossbar and the side plates (see Table 4).

Quantity	Part	Surface	Tightening torque
40	Flange locking bolt M16 x 1.5; Strength class 10.9	Dacromet + TTF	 <b>380 Nm</b>
40	Flange locking nut M16 x 1.5; Strength class 10	Dacromet + TTF	

Table 4: Tightening torque M1; number of nuts and bolts required (screw set for side plates SPM ROE71621)

All **40 nuts and bolts** must be fitted (20 on each side) as illustrated in Fig. 18.

**No washers may be used for the nut and bolt as this will disable the locking function.**

**The tightening torque M1 (see Table 4) must be applied with the aid of a torque wrench and inspected and documented on first fitting and on inspection after 5000 km (see Section 4).**



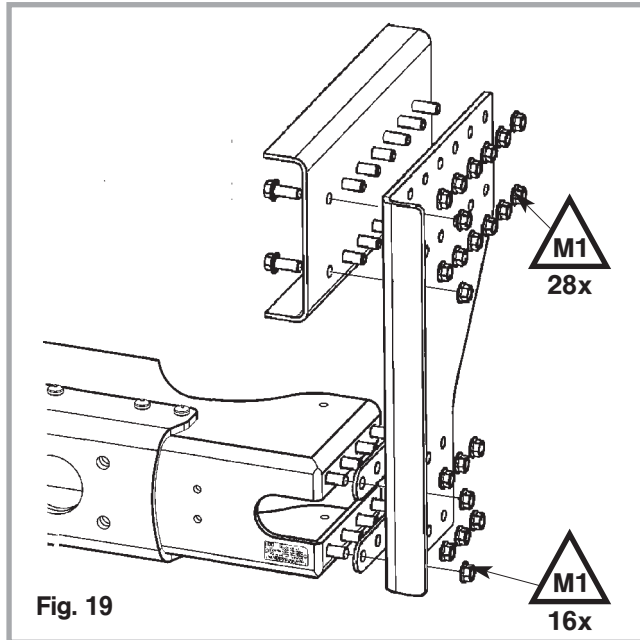

Fig. 19

#### c) Installation of side plates SPL

The **ROCKINGER fastening sets must be used** to fasten the crossbar and the side plates (see Table 5).

Quantity	Part	Surface	Tightening torque
44	Flange locking bolt M16 x 1.5; Strength class 10.9	Dacromet + TTF	 <b>380 Nm</b>
44	Flange locking nut M16 x 1.5; Strength class 10	Dacromet + TTF	

Table 5: Tightening torque M1; number of nuts and bolts required (screw set for side plates SPL/V, ROE71622)

All **44 nuts and bolts** must be fitted (22 on each side) as illustrated in Fig. 19.

**No washers may be used for the nut and bolt as this will disable the locking function.**

**The tightening torque M1 (see Table 5) must be applied with the aid of a torque wrench and inspected and documented on first fitting and on inspection after 5000 km (see Section 4).**

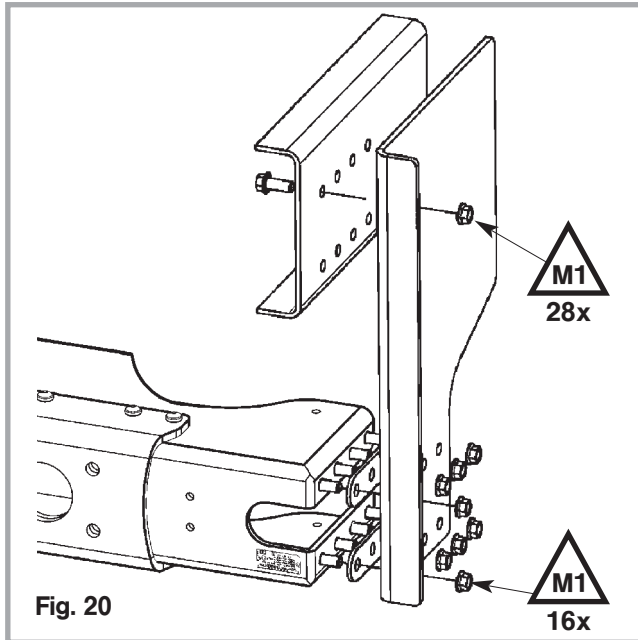

Fig. 20

#### d) Installation of side plates SPV

##### 1. With upper holes pre-bored in the factory

The **ROCKINGER fastening sets must be used** to fasten the crossbar and the side plates (see Table 6).

Quantity	Part	Surface	Tightening torque
44	Flange locking bolt M16 x 1.5; Strength class 10.9	Dacromet + TTF	 <b>380 Nm</b>
44	Flange locking nut M16 x 1.5; Strength class 10	Dacromet + TTF	

Table 6: Tightening torque M1; number of nuts and bolts required (screw set for side plates SPV ROE 71622)

All **44 nuts and bolts** must be fitted (22 on each side) as illustrated in Fig. 20.

**No washers may be used for the nut and bolt as this will disable the locking function.**

**The tightening torque M1** (see Table 6) **must be applied with the aid of a torque wrench and inspected and documented on first fitting and on inspection after 5000 km** (see Section 4).

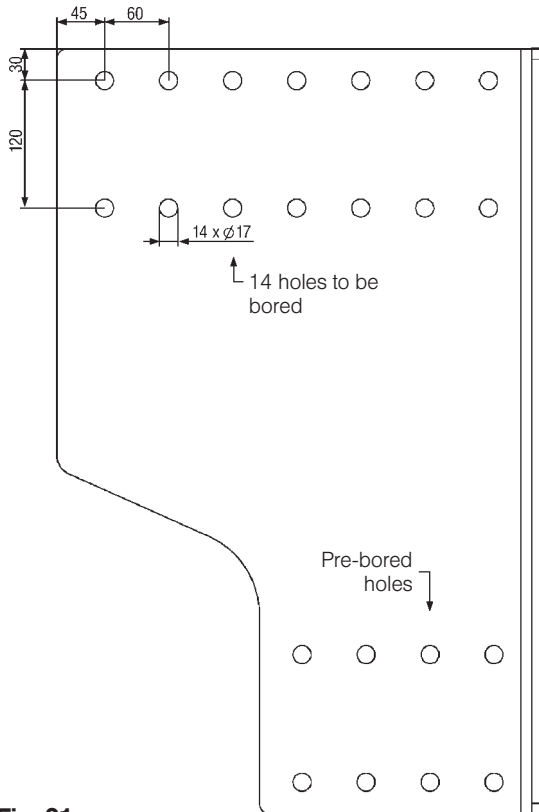

Fig. 21

#### 2. Without upper holes pre-bored in the factory

Before fitting the 14 fastening holes must first be bored in each of the two side plates.

The holes are bored with a drill bit  $\varnothing 17$  in accordance with the hole pattern shown in Fig. 21.

When drilling the holes make sure that the surface protection is not damaged – particularly by bore chips.

When drilling is complete, **ALL of the boreholes must be cleanly deburred.**

**This work must be carried out with great care to ensure that there are no notches in the boreholes. These could lead to a failure of the part.**

In the event of doubt, use the holes pre-bored in the factory.

The side plates and the crossbar must then be fitted as explained under point 3.4.1 (page 39) and the previous section "1. With holes pre-bored in the factory".

**No other hole pattern is permitted as there is no approval for this.**

**CHECK!**

Fig. 22

**Inspection of fastening bolts:**

After the first installation of the crossbar and – in the case of half-lowered and lowered installation - of the side plates, the **tightening torques M1** of ALL fastening bolts must be checked and tightened as necessary (Fig. 22) and documented.

**For inspection intervals and documentation see Table  
"Documentation"**

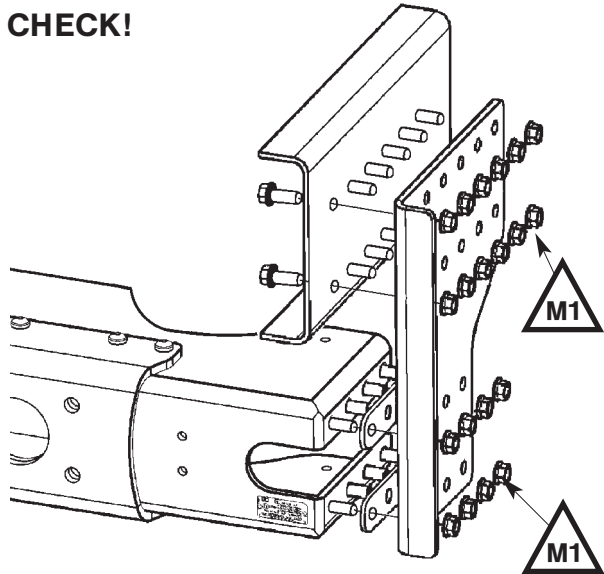
**Visual inspection for damage:**

At the usual service intervals the crossbar and – if present – the side plates must also be given a visual inspection for damage.

**Special attention must be given to the development of cracks,** particularly in the area of the fastening bearing of the hitch.

If there are any cracks, the part concerned must be replaced.

**Parts may NOT be repaired by welding.**

**Table: Documentation**

Maintenance of crossbar and side plates		I) tightening torque M1 checked II) Visual inspection carried out		
Kilometres	Interval	Date	Fitter's signature	Workshop stamp
<b>First installation</b>				
	First installation km + <b>5.000 km</b>			
	First installation km + <b>15.000 km</b>			
	First installation km + <b>60.000 km</b>			
	First installation km + <b>120.000 km</b>			
	First installation km + <b>180.000 km</b>			
	First installation km + <b>240.000 km</b>			
	First installation km + <b>300.000 km</b>			



JOST-Werke · Siemensstr. 2, D-63263 Neu-Isenburg · Telefon +49(0)61 02 295-0 · Fax +49(0)61 02 295-298 · [www.jost-world.com](http://www.jost-world.com)

**ZDE 199 88 238-2-020 · 07/2010**