

Montage- und Betriebsanleitung

D

Installation and operating instructions

GB

Monterings- och driftanvisning

S

ROCKINGER

Member of JOST-World

Modell

Series

Serie

RO*ZF-57

Zugöse mit Flansch

Drawbar eye with flange

Dragöгла med fläns

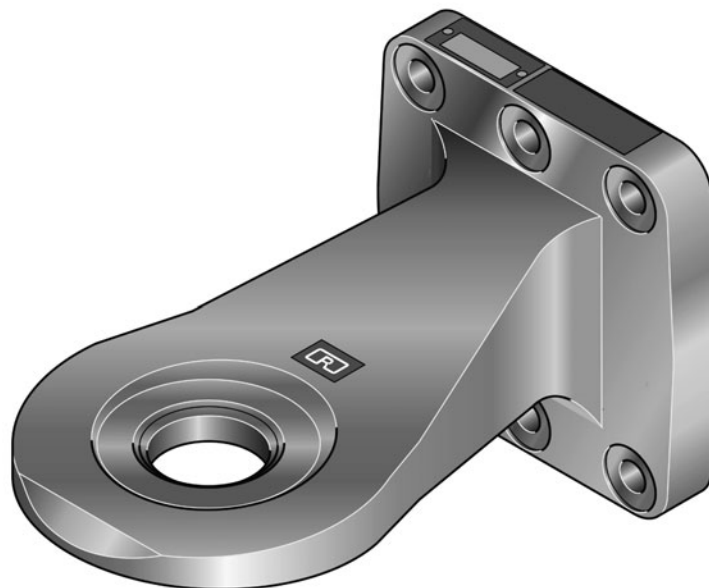

**Drawbar eye RO★ZF-57
with Flange – Order no. 57370**

e1★94/20★00-1356-01 class S

suitable for:

- for direct mounting on trailer frame elements
- for mounting on drawbars
- for use with trailer couplings with a nominal pin diameter of 57 mm



**The drawbar eye must be installed
by authorised workshop!**

**Read these instructions carefully
before fitting!**

Official note

When fitting the drawbar eye the regulations for fitting mechanical fastening systems in accordance with Appendix VII of Directive 94/20/EC and the national regulations must be observed.

Subject to technical changes without prior notice

1. Application areas **8**

2. Technical data **8**

3. Scope of delivery **9**

4. Accessories **9**

5. Fitting tips **9**



1. Application areas

The drawbar eye is approved:

- for direct mounting on trailer frame elements
- **for mounting on drawbars**
- **for use** with trailer couplings with a nominal pin diameter of **57 mm** of series RO★57 e1★94/20★1361★00, RO★57 flex e1★94/20★00-4982 or

trailer couplings with the same functional dimensions guaranteeing the necessary swing arc

The drawbar eye can be used on:

- central-axle trailers
- turntable drawbar trailers
- dollies

Please refer to the table for details of load ratings.

2. Technical data

RO★ZF-57

combination	EC ratings		V (kN)	S (kg)	Additional manufacturer's ratings ¹		Weight (kg)
	D (kN)	Dc (kN)			Av (t)	Pc (kN)	
I	300	131	82	1000	18	30	18.7
II	300	130	50	2000	18	30	18.7
III	300	146.5	65.5	1000	18	30	18.7

¹ for Scandinavia; these figures must be verified during type testing of a complete towing hitch system.

3. Scope of delivery

RO★ZF-57

ROCKINGER order no. ROE 57370

Drawbar eye without mounting plate and screw set
(see Fig. 1 for hole pattern)

4. Accessories

RO★ZF-57

Flange screw set order no. ROE 30414

M16 grade 12.9, tightening torque 365 Nm ± 25 Nm

Note:

Mounting plates (e.g. ROE 59394+59395) are included in the type test approval for the drawbar.

Welding to the drawbar eye is **not permitted!**

Check:

- **After first fitting** drawbar eye **retighten screws after 2500 km** (tightening torque 365 Nm ± 25 Nm).
- **Always check** mounting screws during **routine** maintenance:
If screws are damaged or stretched, **fit new ones immediately! RISK OF ACCIDENT!**



5. Fitting tips

RO★ZF-57

- Do not paint drawbar eye flange or connection plate and ensure that they are grease free when fitting.
- Logo must face upwards.
- Only use flange screw set from ROCKINGER or equivalent screw fastening.
- Observe specified tightening torque (see item 4).

Replacing drawbar eye bush

The bush may only be replaced by a specialist workshop!

- Worn, deformed and damaged bushes must be immediately replaced by new ones.
- Use ROCKINGER tool set no. ROE 57377 to change bush.

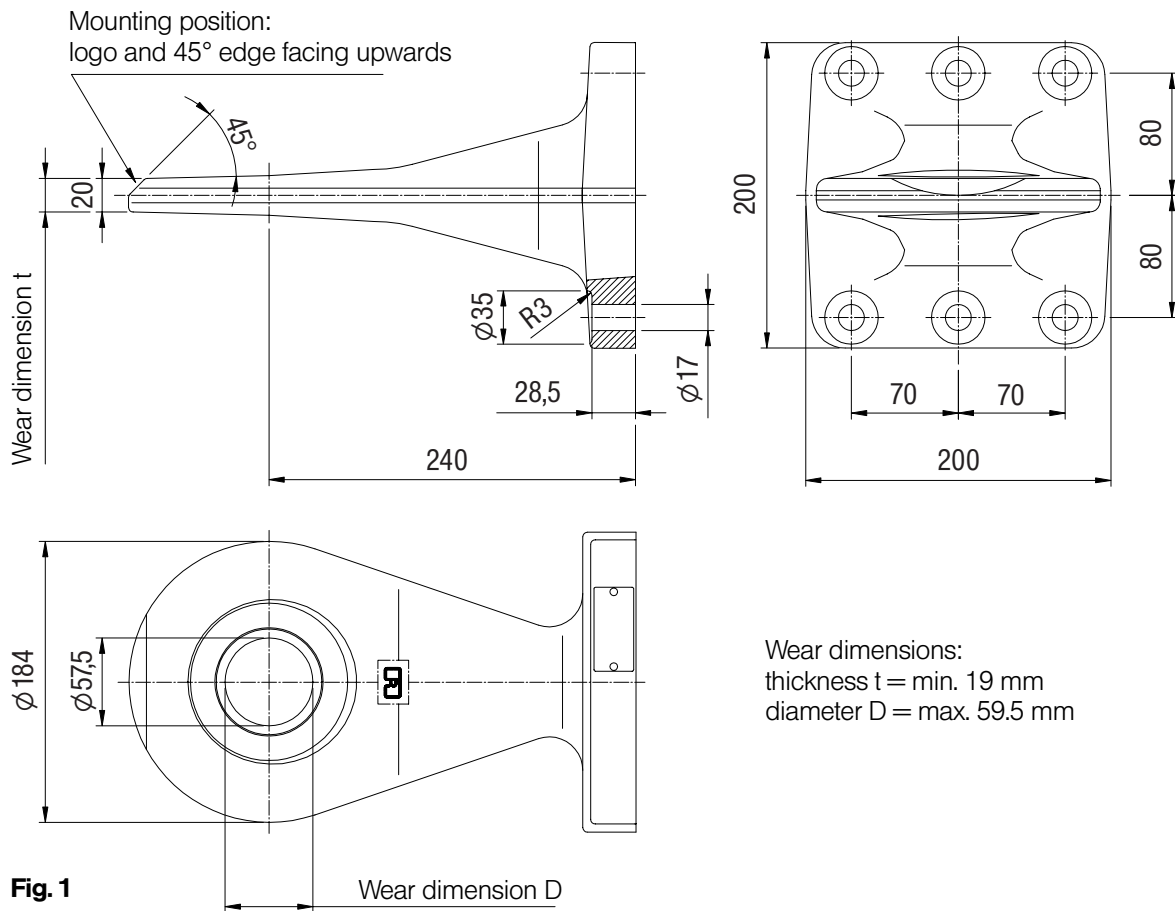



ROCKINGER

JOST-Werke · Siemensstr. 2, D-63263 Neu-Isenburg · Telefon +49 (0) 61 02 2 95-0 · Fax +49 (0) 61 02 2 95-298 · www.jost-world.com

ZDE 199 88199 · 10/2004