



Reparaturanleitung

D

Repair instructions

GB

Instructions de réparation

F

Member of JOST-World

Modellreihe

Series

Type

RO*430/433

Vollautomatische Anhängerkupplung

Automatic Trailer Coupling

Attelage de remorque entièrement automatique

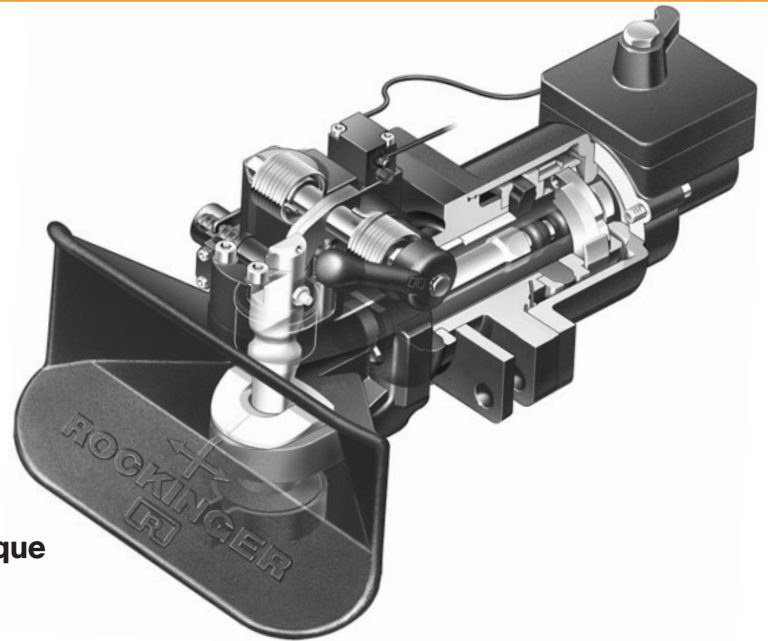

Series RO★430/433
Fully automatic trailer coupling



The coupling must be installed by authorised personnel!

Read these instructions carefully before fitting!

Official note

When fitting the trailer coupling the regulations for fitting mechanical fastening systems in accordance with Appendix VII of Directive 94/20/EC and the national regulations for commercial vehicles must be observed.

Subject to technical changes without prior notice

Safety instructions	16
<hr/>	
1. Replacement of the automatic unit and the coupling pin	17
2. Replacement of the safety system	18
3. Replacement of the hand lever	18
4. Switching the hand lever over to the left	19
5. Replacement of the support ring	19
6. Replacement of the funnel	20
7. Replacement of the lower or /and the upper bush	20
8. Replacement of the pneumatic valve	21
9. Replacement of the pressure bar	22
10. Replacement of the hydraulic unit	23
11. Replacement of the bearing/the springs/ the fastening segments	24 – 26



Validity and liability

Content of these instructions

This repair manual refers exclusively to the trailer coupling RO★430/433, and contains instructions for the correct execution of all the main repair jobs. The technical regulations for the installation of pneumatic systems must be observed.

If lubricants are included with the delivery of a spare part:

- Only use the supplied lubricant in accordance with the instructions provided in this manual.

If fastening elements are included with the delivery of a spare part, e.g. bolts:

- Dispose of the old fastening elements.
- Install the supplied fastening elements.

Liability

ROCKINGER assumes no guarantee for the completeness and correctness of the information. No claims can be derived from the content of the instruction manual. In particular, no liability can be assumed for damages resulting from incorrect repair or maintenance work.

Copyright

All the rights to these instructions and their annexes are held by ROCKINGER



Notices of hazards and risks

Important text passages which must be observed are marked accordingly:

Safety instructions



WARNING!

Incorrectly executed repairs can lead to serious accidents!

- Safe operation of the trailer coupling is only possible if all repairs are carried out exclusively by qualified personnel.
- Repairs to the trailer coupling should only be carried out in accordance with the information provided in this instruction manual.
- All bolts must be tightened with the specified torque. If specified, washers should be used.
- Only use original ROCKINGER spare parts.
- Only operate the trailer coupling if it is in perfect technical condition.
- Observe other documentation: assembly instructions for the trailer coupling as well as for any accessories, operating instructions for the tractor vehicle and for the trailer.



WARNING!

Risk of accident from incorrect conversions!

Trailer couplings are vehicle parts which are subject to the maximum safety requirements.

- ROCKINGER can assume no guarantee for the trailer coupling if the customer carries out unauthorised conversions or alterations.
- Unauthorised conversions or alterations render the model permit invalid.
- Only use original ROCKINGER accessories which are suitable for the trailer coupling concerned.
- Never make any other changes or conversions to the trailer coupling.

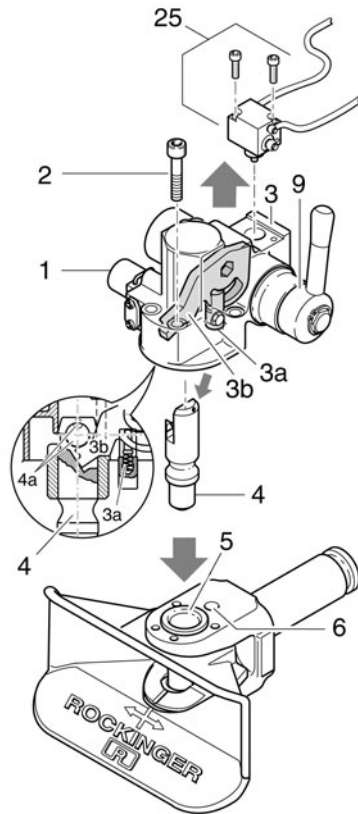

Fig. 1

1. Replacement of the automatic unit and the coupling pin (see fig. 1)

Attention: The hand lever axle (10) should not be dismantled!

Unscrew pneumatic valve (25, tubes do not loose)

- Open coupling with the hand lever (9)

Attention! Do not intrude yourself into the funnel!

THIS INVOLVES RISK OF AN ACCIDENT!

- Loosen 4 hexagonal bolts M 10 (2)
- Remove automatic unit (3) in upward direction
- Gently press automatic unit (3) with coupling pin (4) onto work bench (coupling pin 4 will fall out)

When replacing the coupling pin, the safety system is to be replaced, too (see below)

- Remove old grease out of the automatic unit
 - Insert new coupling pin into the body (upper bush 5)
- Attention:** The coupling pin should be withdrawn on the side of the safety system (1)
- Place automatic unit (3) lifting hand lever (9) slightly and guiding throw-up lever (3b) into groove of coupling pin underneath retaining pin (4a) to enable coupling bolt to be raised from throw up lever and push funnel stop device into bore (6)
 - Fasten automatic unit (3) gently with screws (2)
 - Press hand lever (9) gently upwards: check the movement of the safety system (1)
 - Fasten automatic unit (3) with screws (2):
Tightening torque **49 Nm**
Use screws M 10 x 60 DIN 912, grade 8.8!
 - Screws-in from a loosable position
 - Screw on pneumatic valve (25): tightening torque **10 Nm**
 - Grease via lubrication nipple on the automatic unit only when coupling is open (coupling pin in the upward position, ca. 120 g NLGI 2)

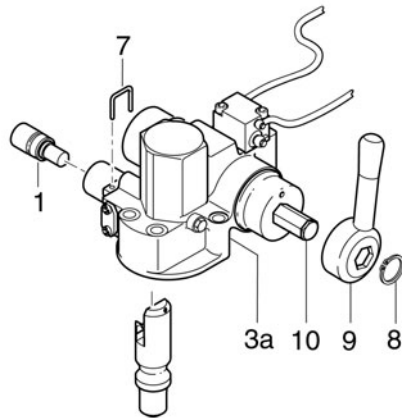

Fig. 2

2. Replacement of the safety system (see fig. 2)

- Safety shackle is to be bent up and wire bar (7) withdrawn
- Safety system (1) should be completely extracted out of the housing
- Push the new safety system up to the stop into the bore (safety system is fastened)
- Insert the new wire bar (7)
- Wire ends of the safety shackle are to be bent over

Check:

- Press hand lever (9) gently upwards: check-up the movement of the safety system (1)

3. Replacement of the hand lever (see fig. 2)

- Remove circlip (8) with circlip pliers **A1** from hand lever axle (10)
- Dismantle hand lever (9)
- Fit new hand lever
- Fasten new circlip with circlip pliers **A1**
(do not stretch circlip too much)

Switching hand lever / Replacement support ring RO*430 / 433

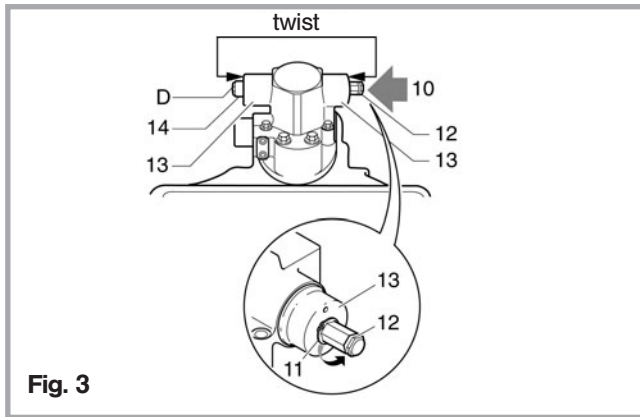

Fig. 3

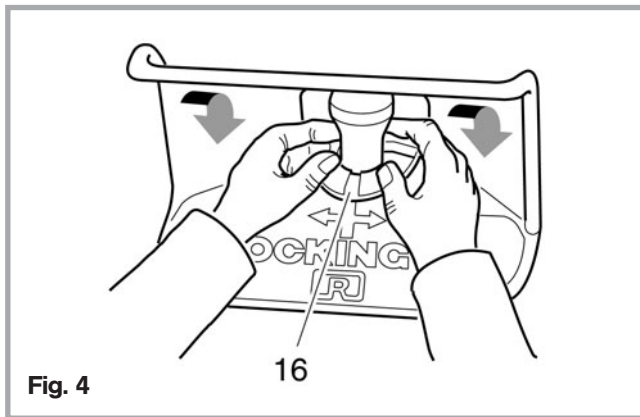

Fig. 4

4. Switching the hand lever over to the left (see fig. 3)

(repairset 71079)

- Remove circclip (8, see page 1) with circclip pliers **A1** from hand lever shaft (10)
- Dismantle hand lever (9)
- Clamp bearing washers (13) with suitable assembling tool (see illustration) on left and right
- Remove circclip (11) with circclip pliers **A1**
- Insert new circclip (18 x 1,5) into the groove (12)
- Knock hand lever axle (10) through carefully
- Dismount spacer (D)
- Remove circclip (14) with circclip pliers **A1**
- Insert new circclip (18 x 1,5) in the inside position
- Push hand lever into position
- Fasten new circclip (18 x 1,5) circclip pliers **A1**: (take care to ensure a firm seat)

5. Replacement of the support ring (see fig. 4, 5)

(only by RO*430)

- Close coupling: **otherwise risk of accident!**
 - Raise coupling pin with suitable tool **or**
 - Strike hand lever knob briefly in opening direction with heel of your hand
- Remove the support ring (15) with the help of the chisel which is to be placed on the lateral recesses
- Lift coupling pin with hand lever
- Take out support ring
- Clean support ring surface and groove
- Fit new support ring (with position marking **16** facing forwards)
- Both slot pins are to be knocked into the support ring (15) laterally

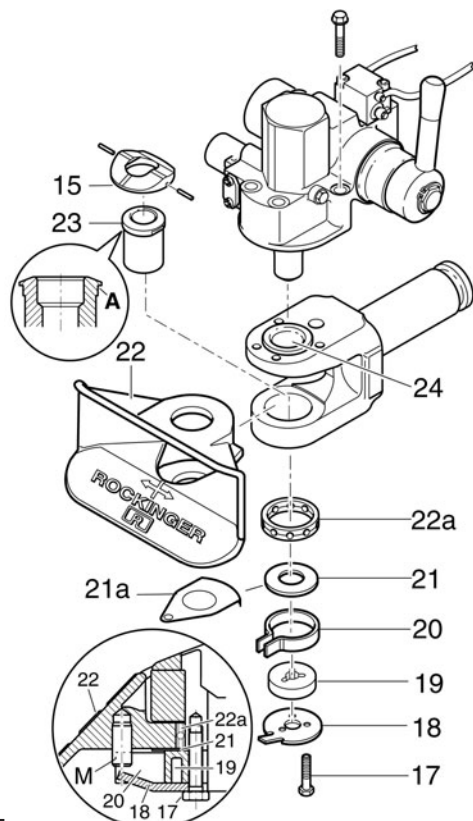

Fig. 5

6. Replacement of the funnel

- Dismantle automatic unit (**see point 1**)
 - Dismantle pressure bar (**see point 9**)
 - Loose 3 screws (**17**) on base plate (**18**)
 - Remove bottom part together with guide bush (**19**), spring (**20**) and washer (**21**) or transmitter disk (**21a**) for turn-angle alarm system
 - Take out funnel (**22**)
 - Upward and downward support wear are to be greased
 - Raise coupling bolt with hand lever and lift out funnel (**22**)
 - Insert new funnel (support ring **22a** is mounted in the funnel)
 - Proceed with assembly in reserved sequence (pay attention to bore alignment; insert transmitter disk **21a** in correct position)
- When inserting screws, funnel should be located in central position: Spring is to surrounded the retaining pin (**M**) on funnel
- Opening coupling: Funnel lock should be inserted
 - Tighten screws (**17**) when the funnel is in the central position:

Tightening torque 30 Nm

- Please, check the lock and movement of the funnel

7. Replacement of the lower or / and the upper bush

- Dismantle coupling from crossbar (**see point 11**)
- Disassemble automatic unit together with coupling bolt, pressure bar, funnel and support ring
- Squeeze lower bush (**23**) or / and upper bush (**24**)
- Press-in a new lower bush facing right direction (bush grooves **A** are to be parallel to the couplings central axle) or / and press in new upper bush
- Re-assemble and mount coupling, check its function

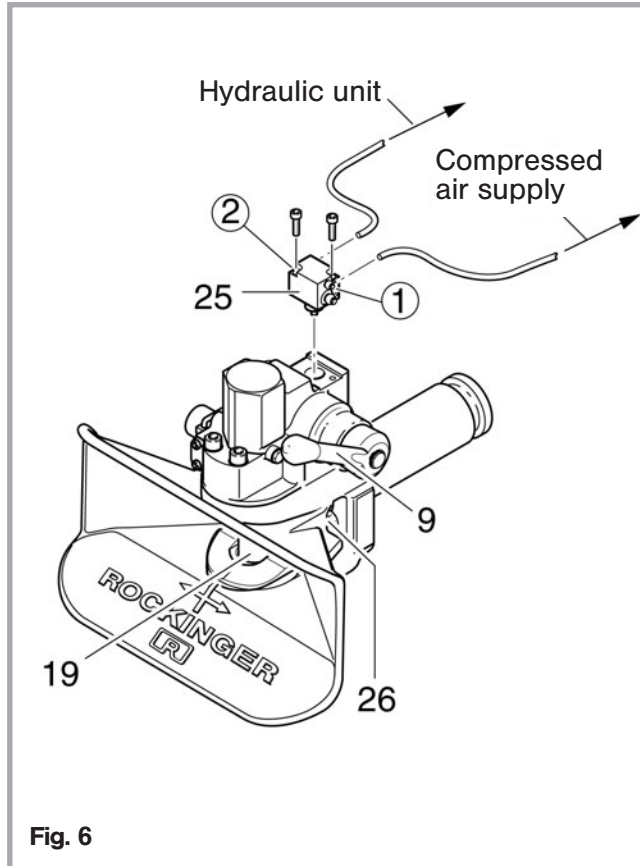

Fig. 6

8. Replacement of the pneumatic valve (see fig. 6)

- Loose tubes on the pneumatic valve (25)
- Unscrew the pneumatic valve
- The new valve is to be fastened with 2 hexagonal bolts M 6:
Tightening torque **10 Nm**
- Remove plastic plugs from the valve
- Tubes are to be installed:
 - from valve connection ② to hydraulic unit
 - from valve connection ① to compressed-air supply

Checking-up with compressed air

- Coupling closed: pressure bar (26) protrudes 15 mm
- Hand lever (9) is to be raised slightly: compressed air can be heard to escape and it relieves hydraulic unit, pressure bar (26) can be pressed back (use appropriate tool, danger of accident).
- Hand lever should be released: pressure bar (26) moves in the direction of a coupling pin

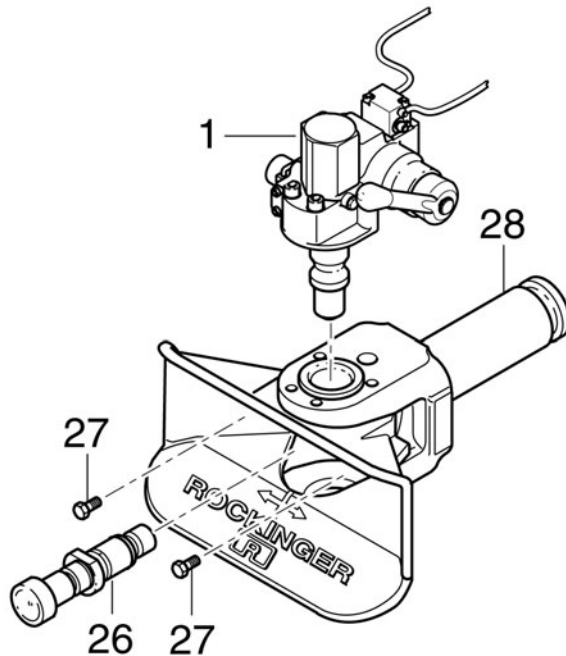

Fig. 7

9. Replacement of the pressure bar (see fig. 7)

- Unscrew automatic unit (hexagonal bolts M 10, **see point 1**)
- Loose completely the screws M 8 (27) with plug nut for thread M 8 on the pressure bar (26)
- Pressure bar with bearing bush is to be withdrawn from the drawbar shaft (28).
In case the pressure bar sits firmly, e. g. because of corrosion, unscrew the hydraulic unit (**see point 10**), the bearing bush should be pressed-out through the bore of the drawbar shaft
- Bore of the drawbar shaft is to be cleaned
- Insert a new pressure bar (truncated surface of the bearing bush upwards) and fasten with new screws M 8 (part no. 30371): tightening torque **25 Nm**
- The automatic unit is to be mounted now (**see point 1**)
- Bearing (lubrication point **K**) should be lubricated with grease, until a new grease appears on the pressure bar

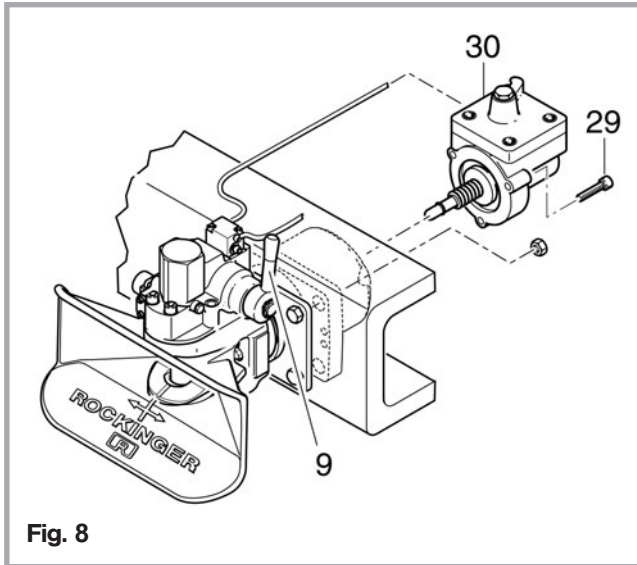

Fig. 8

10. Replacement of the hydraulic unit (see fig. 8)

- Open coupling with the hand lever (9)
- Loosen the tube on the hydraulic unit (30)
- Loosen 3 hexagonal bolts (29)
- Remove the hydraulic unit (30)
- Place the new hydraulic unit in its right position and fasten it with new bolts M 10 DIN 912, grade 8.8, Tightening torque **49 Nm**
- Tube is to be connected
- Function should be checked-up (see point 8)

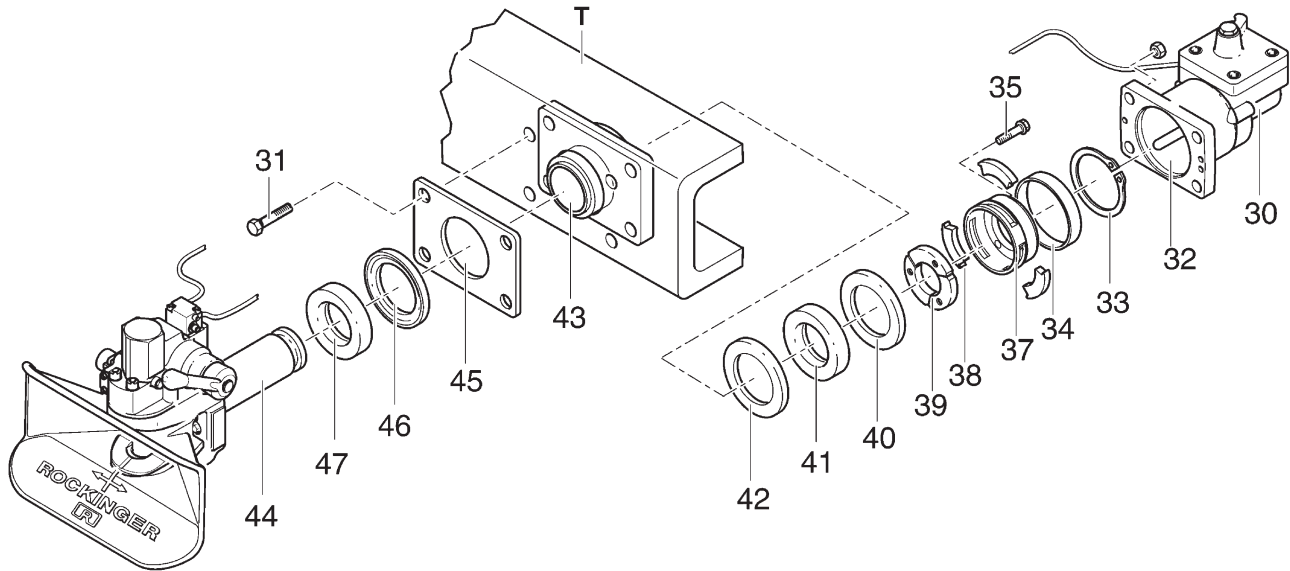

Fig. 9

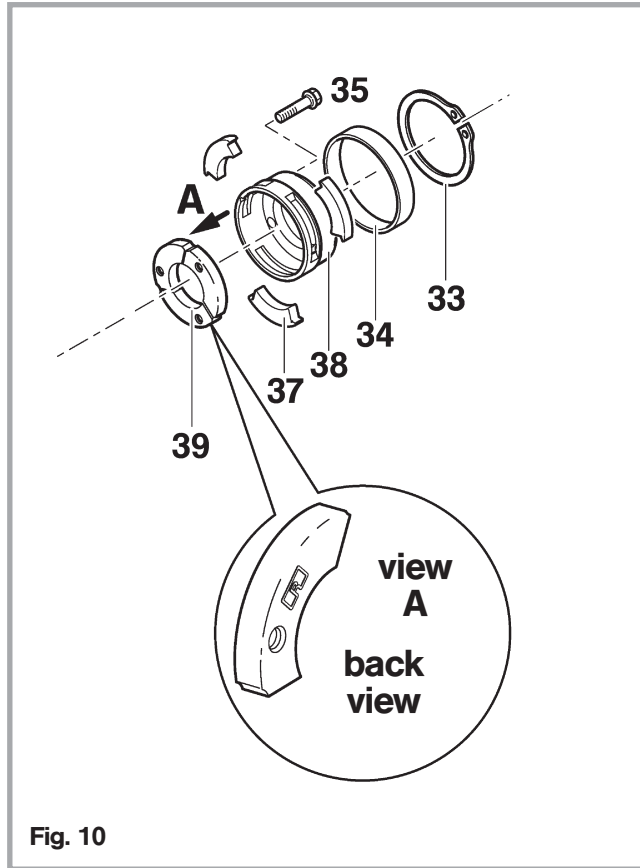

Fig. 10

11. Replacement of the bearing/the springs/ the fastening segments (see fig. 10)

- Loose tubes on the pneumatic valve
- Loose 4 hexagonal bolts (31)
- Remove hydraulic unit (30) together with spring housing (32)
- Remove circlip (33) with circlip pliers A1 and retaining ring (34)
- Unscrew 3 temporary bolts (35) from the spring housing (32) (width across flats 17 mm)
- Screw 3 temporary bolts (35) into the clamping bush (37) step by step until stop position achieved (ca. 80 Nm) and until 3 clamping keys (38) can easily be taken out
- Unscrew once again 3 temporary bolts (35) and withdraw the clamping bush (37), then remove 3 fastening segments (39)
- Remove thrust washer (40), rubber buffer (41), spring cap (42) from the drawbar shaft (44)
- Withdraw the coupling from the crossbar (T)
- Take off the spring cap (46), support plate (45) from attachment bearing (43)
- Withdraw the rubber buffer (47) from the drawbar shaft
- Take out the attachment bearing (43) from the crossbar (T)

Replacement bearing / springs / fastening segments RO★430 / 433

Before the coupling assembly please replace the parts that need to be repaired (for the groups of spare parts see the spare parts list)

- Preliminarily fasten attachment bearing (43) to crossbar (T) from inside and support plate (45) to crossbar (T) from outside using 2 of 4 mounting screws
- Lubricate the drawbar shaft (44)
- Move the rubber buffer (47) on the drawbar shaft (44)
- Set the spring cap (46) onto attachment bearing (43) with concave side towards rubber buffer
- Slide drawbar shaft (44) and rubber buffer (47) into attachment bearing (43):
Note: Do not remove special grease.
- Spring cap (42) is to be mounted onto attachment bearing (43) with concave side towards rubber buffer (41)
- Slide rubber buffer (41) onto drawbar shaft (44)
- Push the thrust washer (40) with concave side towards rubber buffer (41)

Fitting of fastening segments

- **Note:** Locate fastening segments (39) in splines of drawbar shaft (15): The inscribed surface (R) in the direction of the hydraulic unit (30)
- Slide clamping bush (37) carefully over fastening segments (39) onto drawbar shaft (44):
Observe the locking snugs in clamping bush (37) and check-up if bores of clamping bush (37) and fastening segments (39) match.
- Lightly grease the end face and thread of 3 temporary bolts (35), screw them in by hand as far as the stop-end and tighten alternately until slots in clamping bush (37) are free.
- Lubricate thoroughly the retaining ring (34), clamping bush (37), fastening segments (39) and clamping keys (38) **(to protect against corrosion)**
- Insert 3 clamping keys (38) into slots and hold them in their position

- Slide retaining ring (34) over clamping bush (37)
- Fasten circlip (33) with circlip pliers ZGA 4 (see above)
- Unscrew 3 temporary bolts (35) from clamping bush (37) and fastening segments (39), grease them well enough and screw into spring housing (32) (it is required for later dismounting).
- Unscrew 2 bolts from attachment bearing (43)
- Slide on hydraulic unit (30) with spring housing (32):

Caution: Take care not to damage bellows and that the indicated "top" is positioned correctly!

- Fasten with 4 hexagon head cap screws and self-locking nuts

Caution: Screw heads should be on the coupling head side (outer side of crossbar) to avoid impairing of the coupling movability.

Tightening torques:

G 145	M 16	210 Nm (grade 8.8)	310 Nm (grade 10.9)
G 150	M 20	410 Nm (grade 8.8)	580 Nm (grade 10.9)



ROCKINGER GmbH, Waldmeisterstraße 80, D-80935 München

JOST-Werke · Siemensstr. 2, D-63263 Neu-Isenburg · Telefon (0 61 02) 2 95-0 · Fax (0 61 02) 2 95-98 · www.jost-world.com

ZDE 199 88 283 · 06/2008